

La sorgente luminosa contenuta in questo apparecchio deve essere sostituita solo dal costruttore o dal suo servizio di assistenza o da personale altrettanto qualificato.  
The light source contained in this luminaire shall only be replaced by the manufacturer or his service agent or a similar qualified person.

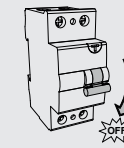

In caso di manutenzione togliere tensione.  
Always switch-off the power supply before carrying out any maintenance.  
Si consiglia di effettuare l'installazione a cura di personale qualificato.  
The installation should be done by qualified personnel.

Alimentazione 220-240V 50/60 Hz  
Power supply 220-240V 50/60 Hz

04-26

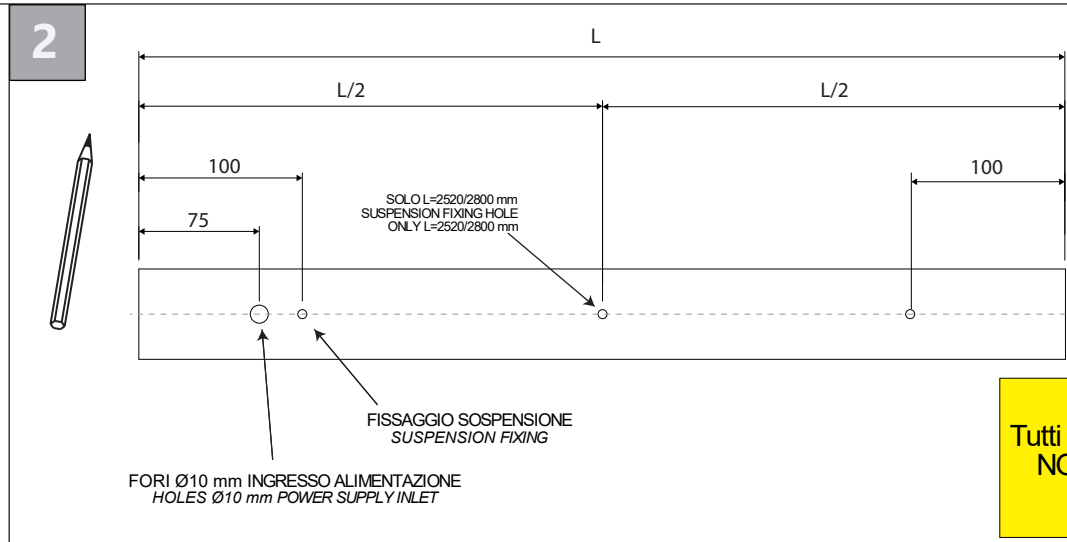
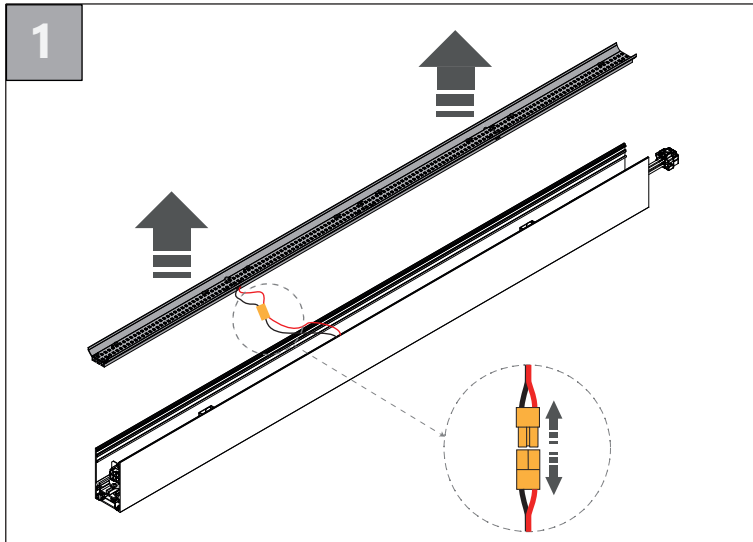

**L (mm)**

HERO+B ANG. L= 594x594
HERO+B L= 868
HERO+B L= 1120
HERO+B L= 1400
HERO+B L= 1428
HERO+B L= 1680
HERO+B L= 1960
HERO+B L= 2240
HERO+B L= 2520
HERO+B L= 2800

**ATTENZIONE:**  
Tutti i prodotti della famiglia HERO  
NON sono tagliabili su misura  
All products in the HERO family  
cannot be cut to size.

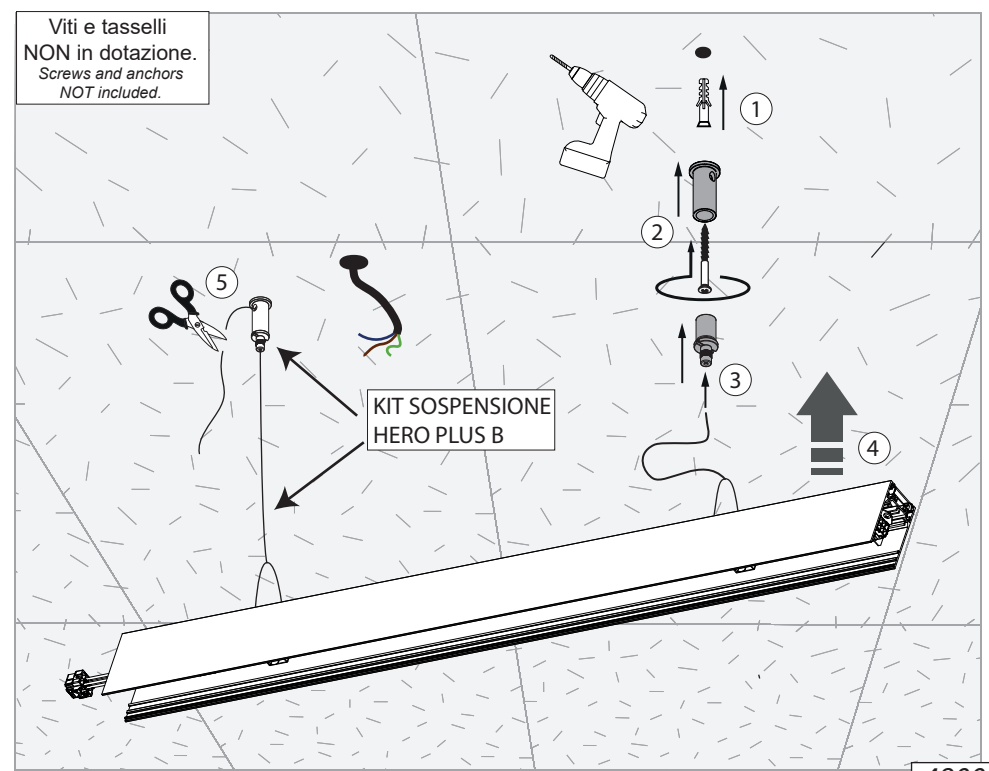
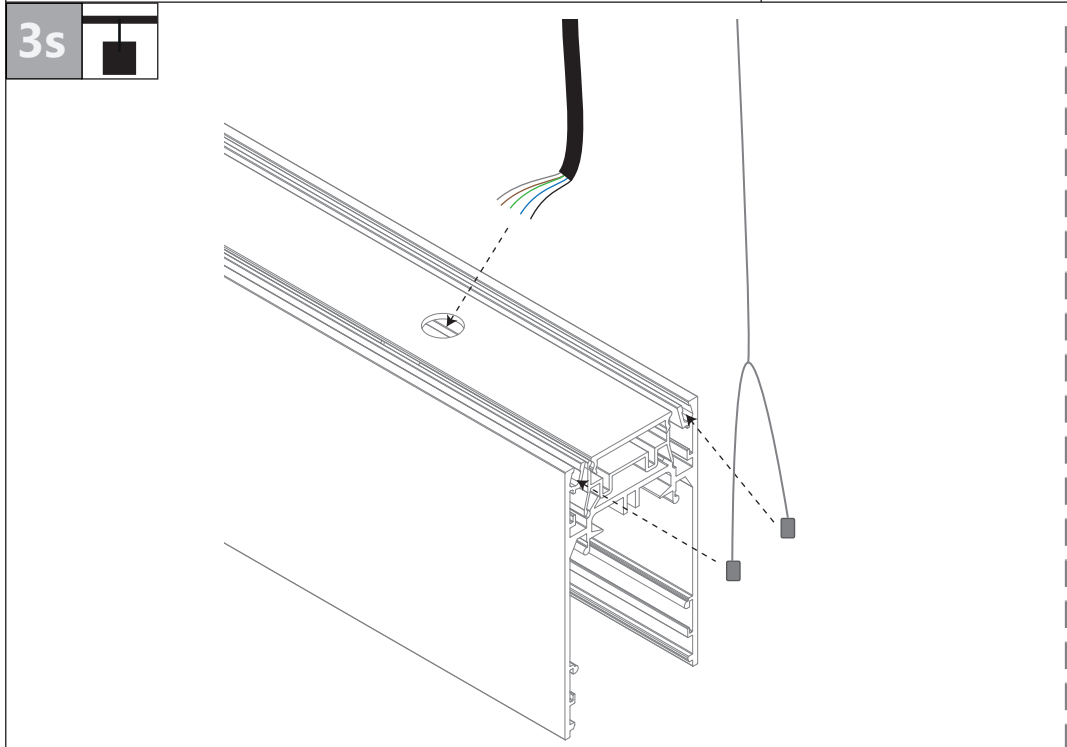

Indiretta

LI



LD

Diretta

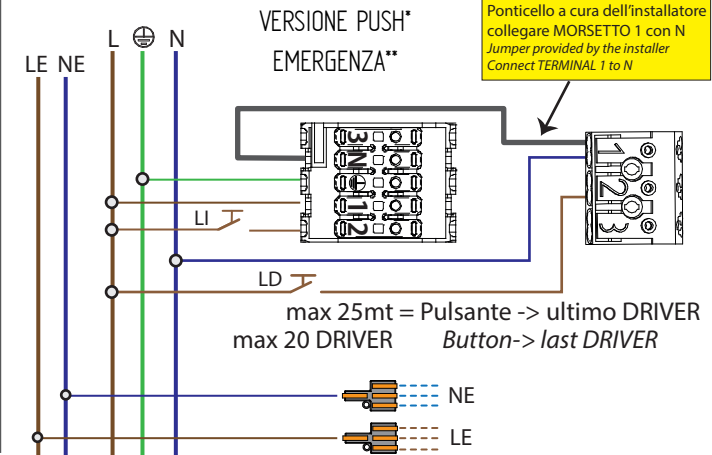
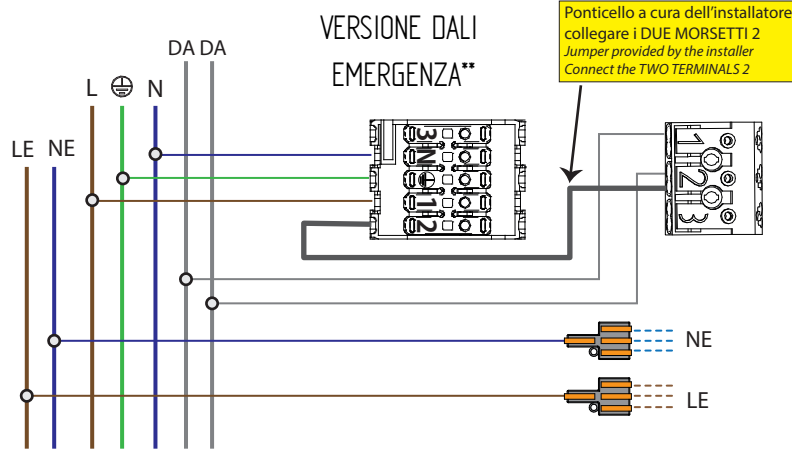
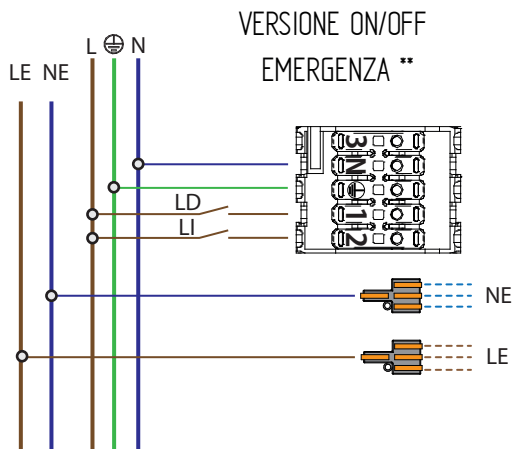
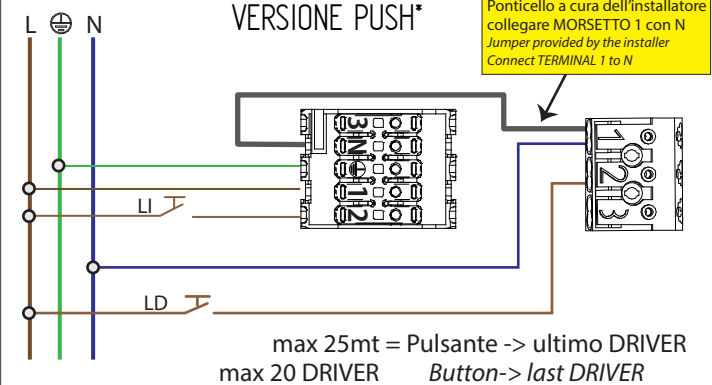
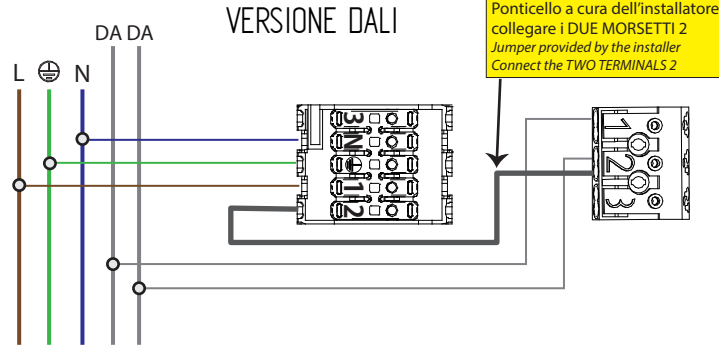
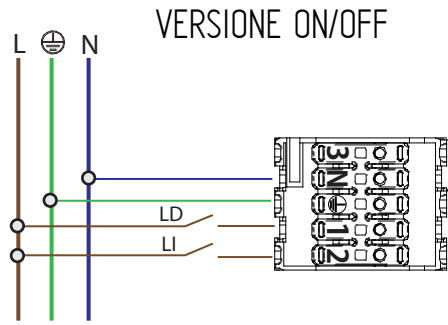

## \*SINCRONIZZAZIONE PUSH

In installazioni con driver LED con livelli di dimmerazione diversi o direzioni di dimmerazione opposte tutti i driver LED possono essere sincronizzati al 50% del livello di dimmerazione con una pressione di 10 s.

L'utilizzo di un pulsante con spia luminosa non è consentito.

In installations with LED drivers with different dimming levels or opposite dimming directions (e.g. after a system extension), all LED drivers can be synchronized to 50% dimming level by a 10 s push. Use of pushbutton with indicator lamp is not permitted

## \*\*Emergenza

Secondo la norma 60598-2-22 par. 22.6.10 [...] la sostituzione della batteria o dell'intero apparecchio di illuminazione [...] è necessaria quando questi non raggiungono la durata di funzionamento assegnata dopo il corrispondente periodo di ricarica.

According to standard 60598-2-22, paragraph 22.6.10, [...] replacing the battery or the entire lighting fixture [...] is necessary when they do not reach the designated operating time after the corresponding charging period.

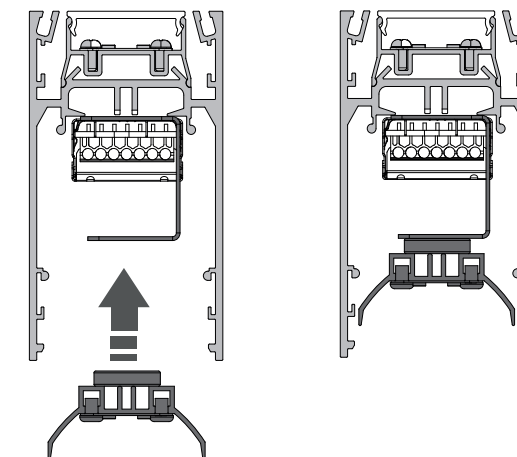
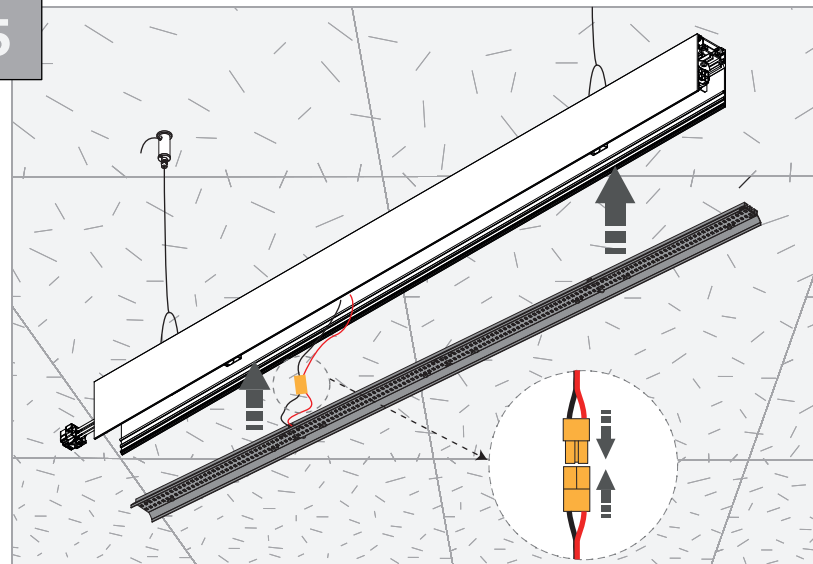

KIT UNIONE HERO PLUS  
108940.99

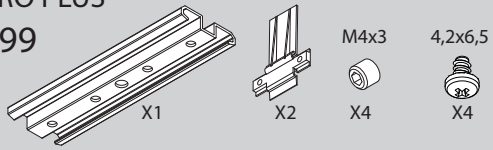

A

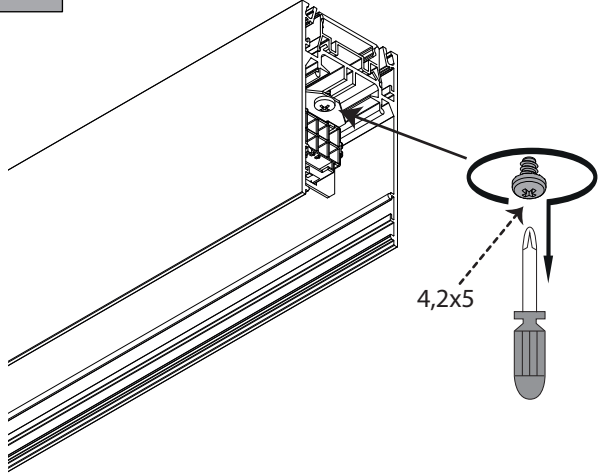

B

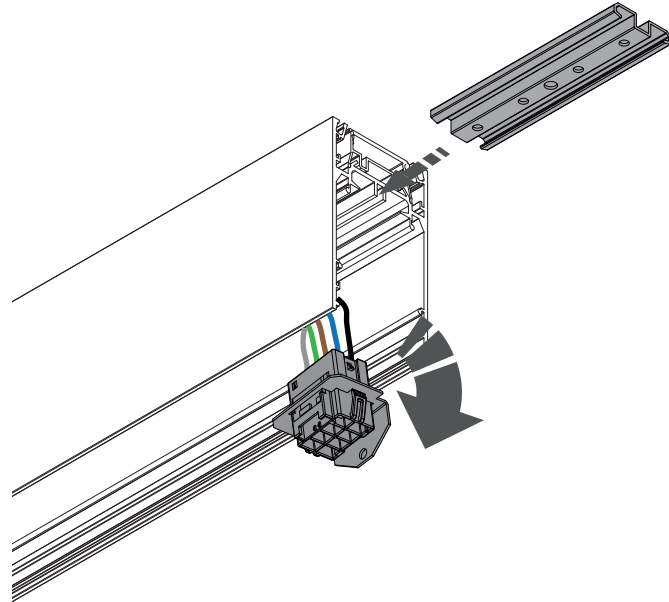

C

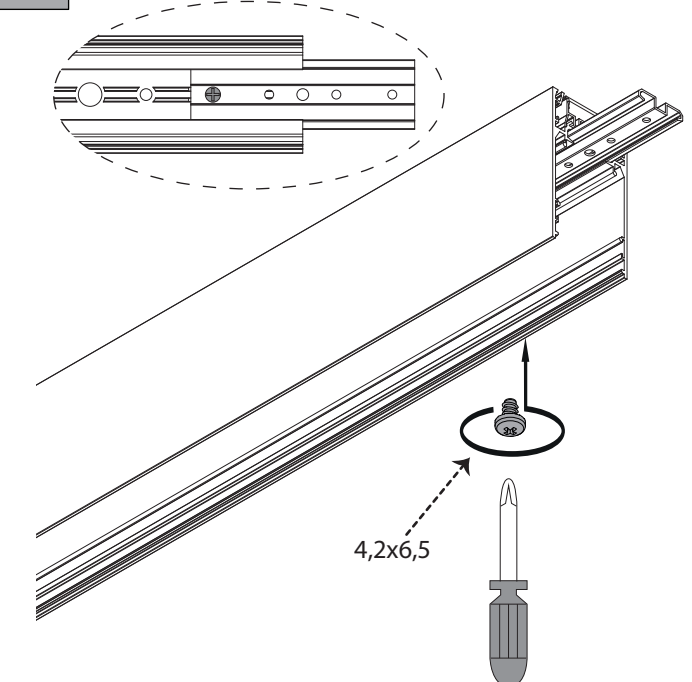

D

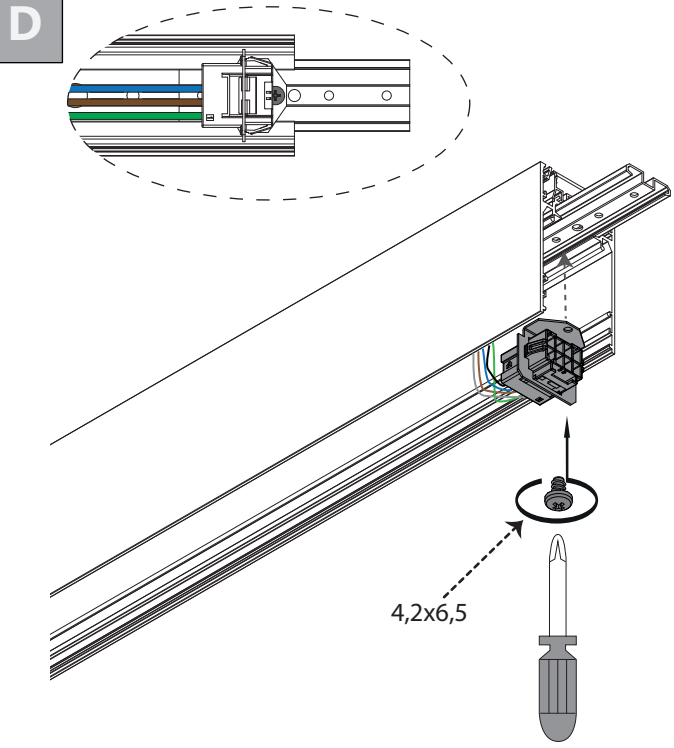

E

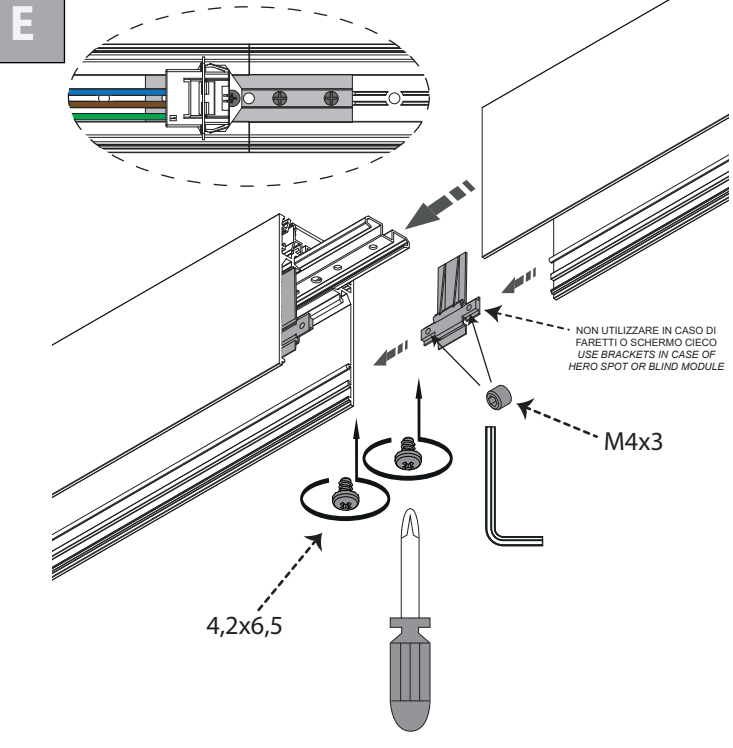

F

