



Ta
25°C

IP40



MAX 1200W
fila continua / continuous line

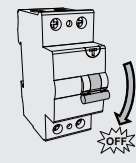

In caso di manutenzione togliere tensione.
Always switch-off the power supply before carrying out any maintenance.
Si consiglia di effettuare l'installazione a cura di personale qualificato.
The installation should be done by qualified personnel.

Alimentazione 220-240V 50/60 Hz
Power supply 220-240V 50/60 Hz

L (mm)
HERO MINI: 636
HERO MINI: 1272
HERO MINI: 1908

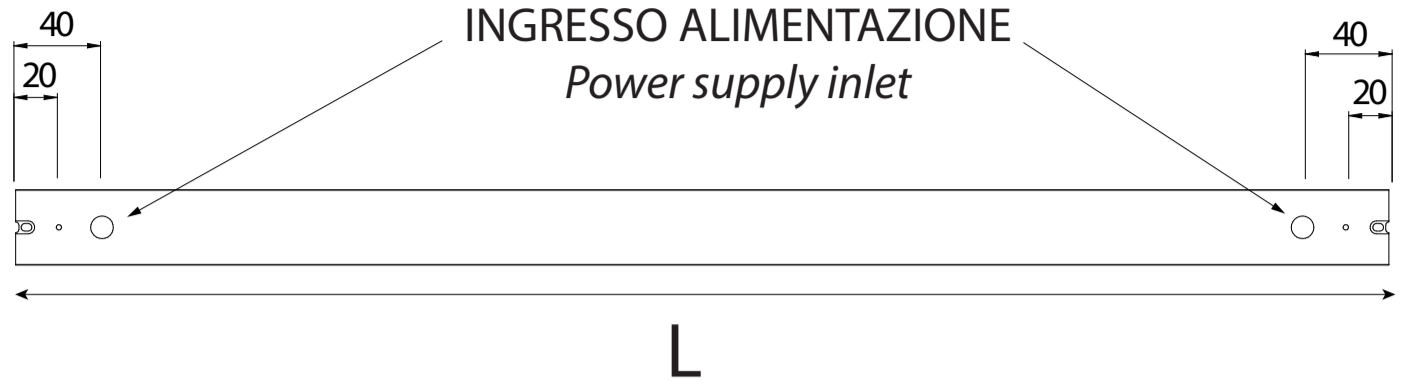

INSTALLAZIONE A PLAFONE Ceiling installation

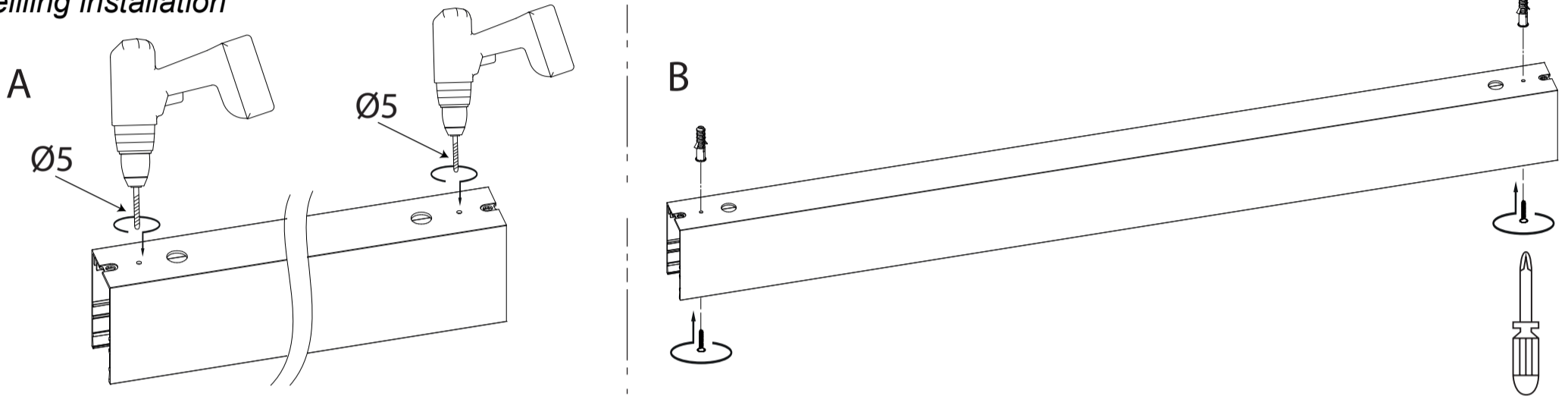

INSTALLAZIONE A SOSPENSIONE Suspended installation

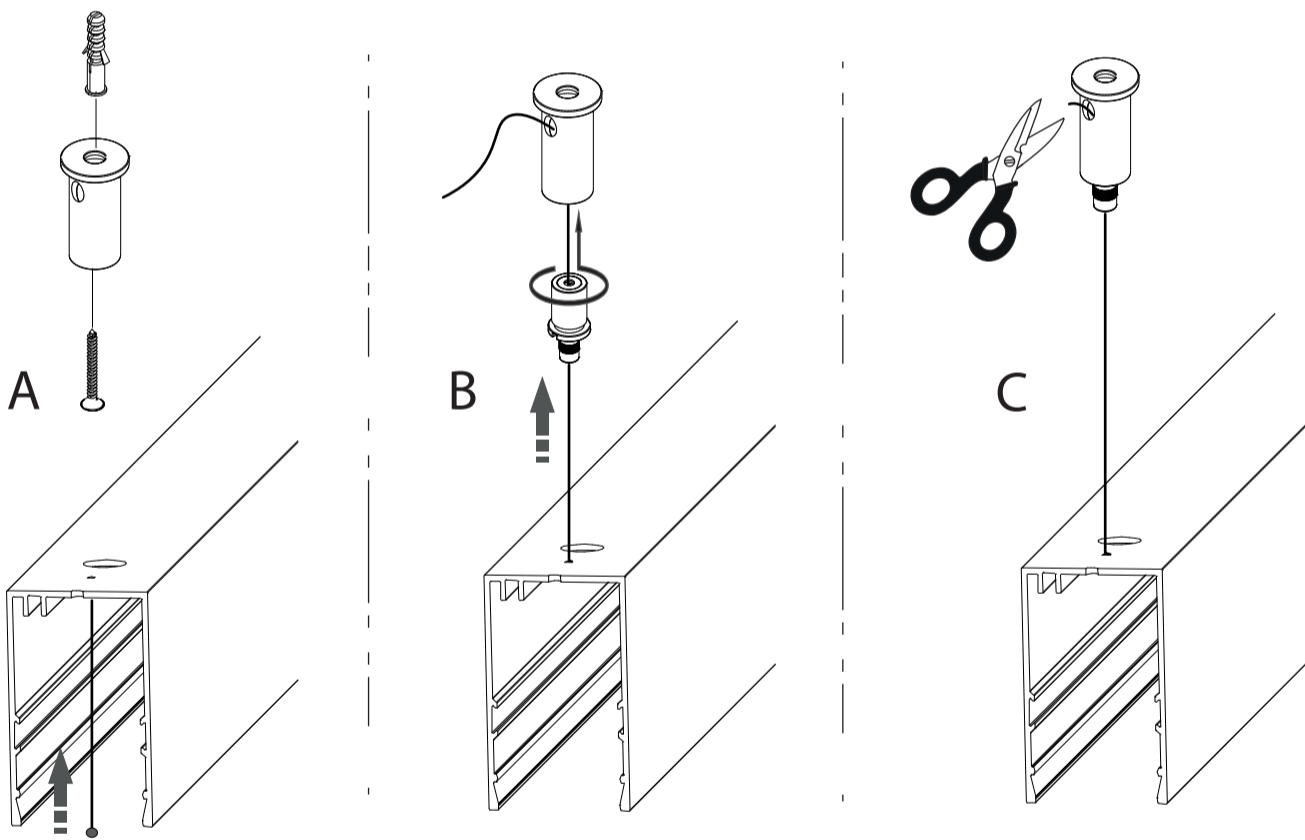

INSTALLAZIONE TESTATE End caps Installation

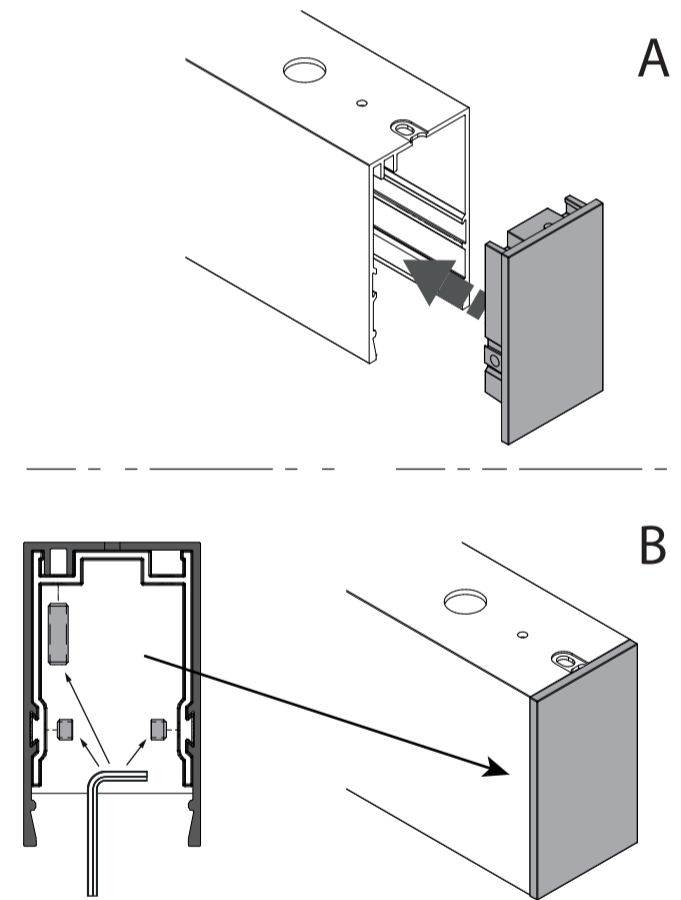

INSTALLAZIONE KIT GIUNZIONE Junction kit installation

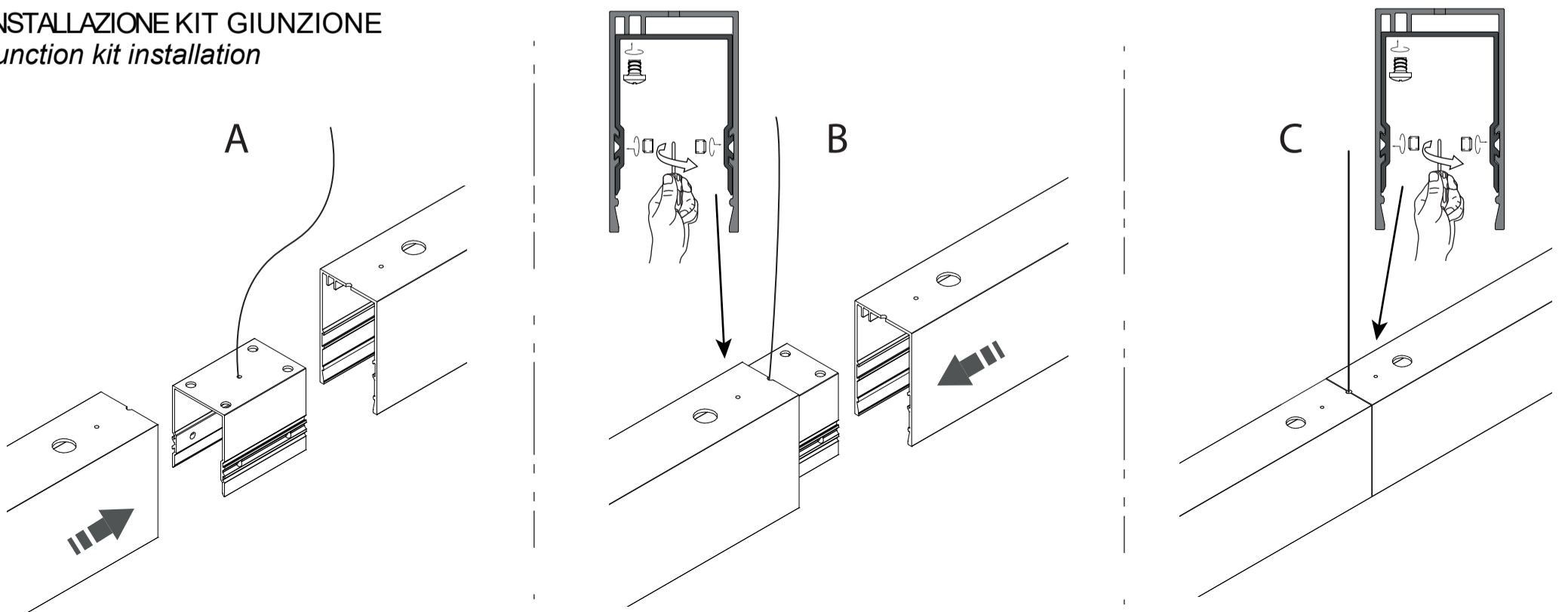

MAX 1200W
fila continua / continuous line



La sorgente luminosa contenuta in questo apparecchio deve essere sostituita solo dal costruttore o dal suo servizio di assistenza o da personale altrettanto qualificato.
 The light source contained in this luminaire shall only be replaced by the manufacturer or his service agent or a similar qualified person.

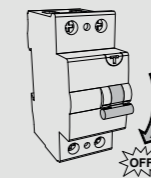

In caso di manutenzione togliere tensione.
 Always switch-off the power supply before carrying out any maintenance.

Si consiglia di effettuare l'installazione a cura di personale qualificato.
 The installation should be done by qualified personnel.

Alimentazione 220-240V 50/60 Hz
Power supply 220-240V 50/60 Hz

VISTA FRONTALE HERO MINI
 MODULO LED E SCHERMO OPALE
 Hero mini front view
 LED module and opal screen

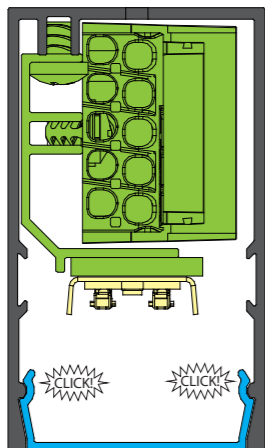

PROFILO DI ALUMINIO
 Aluminum profile

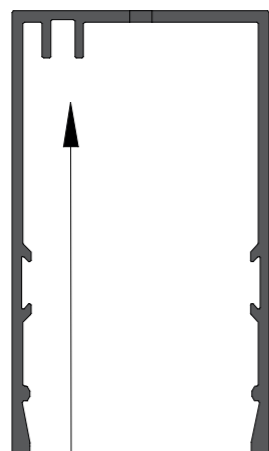

MODULO ELETRIFICATO
 Electrified module

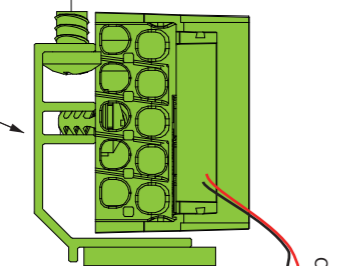

MODULO LED
 LED module



DIFFUSORE OPALE
 Opal diffuser

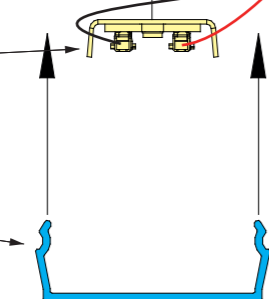

VISTA FRONTALE HERO MINI
 MODULO LED MICRO OTTICHE
 Hero mini front view
 Micro optics LED module

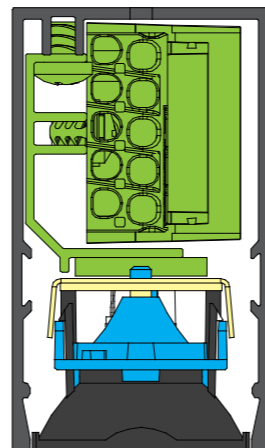

PROFILO DI ALUMINIO
 Aluminum profile

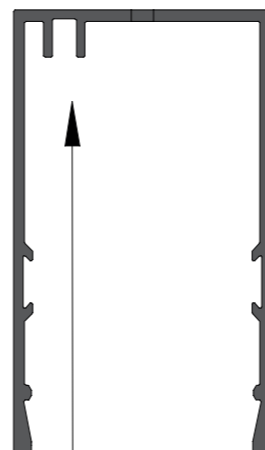

MODULO ELETRIFICATO
 Electrified module

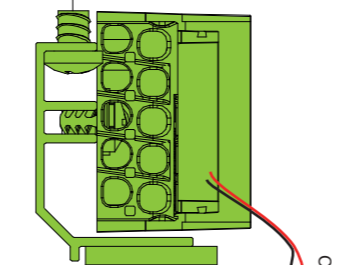

MODULO LED MICRO OTTICHE
 Micro optics LED module

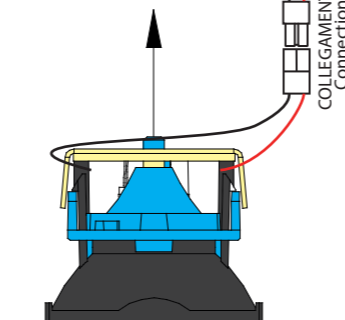

VISTA FRONTALE HERO MINI
 MODULO SPOT LED KLIMT
 Hero mini front view
 Klimt spot LED module

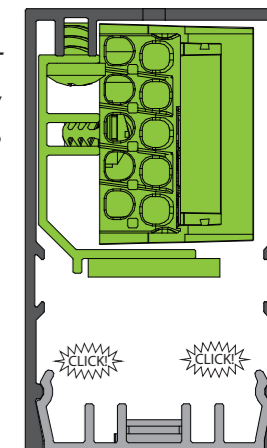

PROFILO DI ALUMINIO
 Aluminum profile

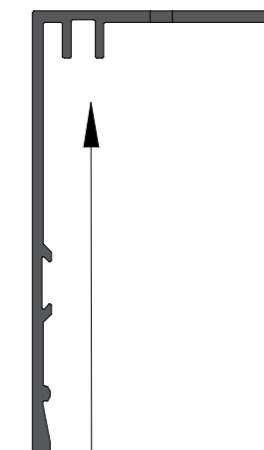

MODULO ELETRIFICATO
 Electrified module

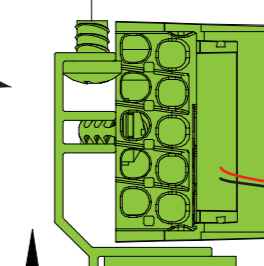

MODULO SPOT
 Module spot

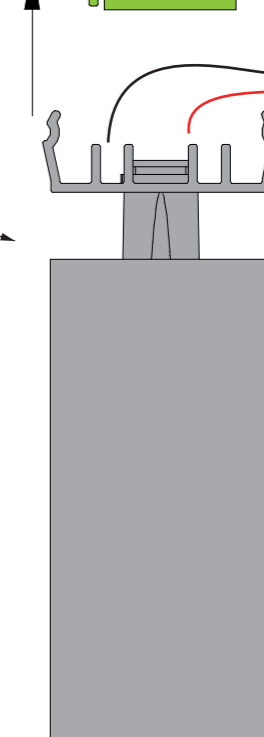

COLLEGAMENTO
 Connection



Ta
25°C

IP40



MAX 1200W
fila continua / continuous line

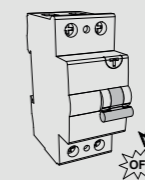

In caso di manutenzione togliere tensione.
Always switch-off the power supply before carrying out any maintenance.

Si consiglia di effettuare l'installazione a cura di personale qualificato.
The installation should be done by qualified personnel.

Alimentazione 220-240V 50/60 Hz
Power supply 220-240V 50/60 Hz

06-24

mm

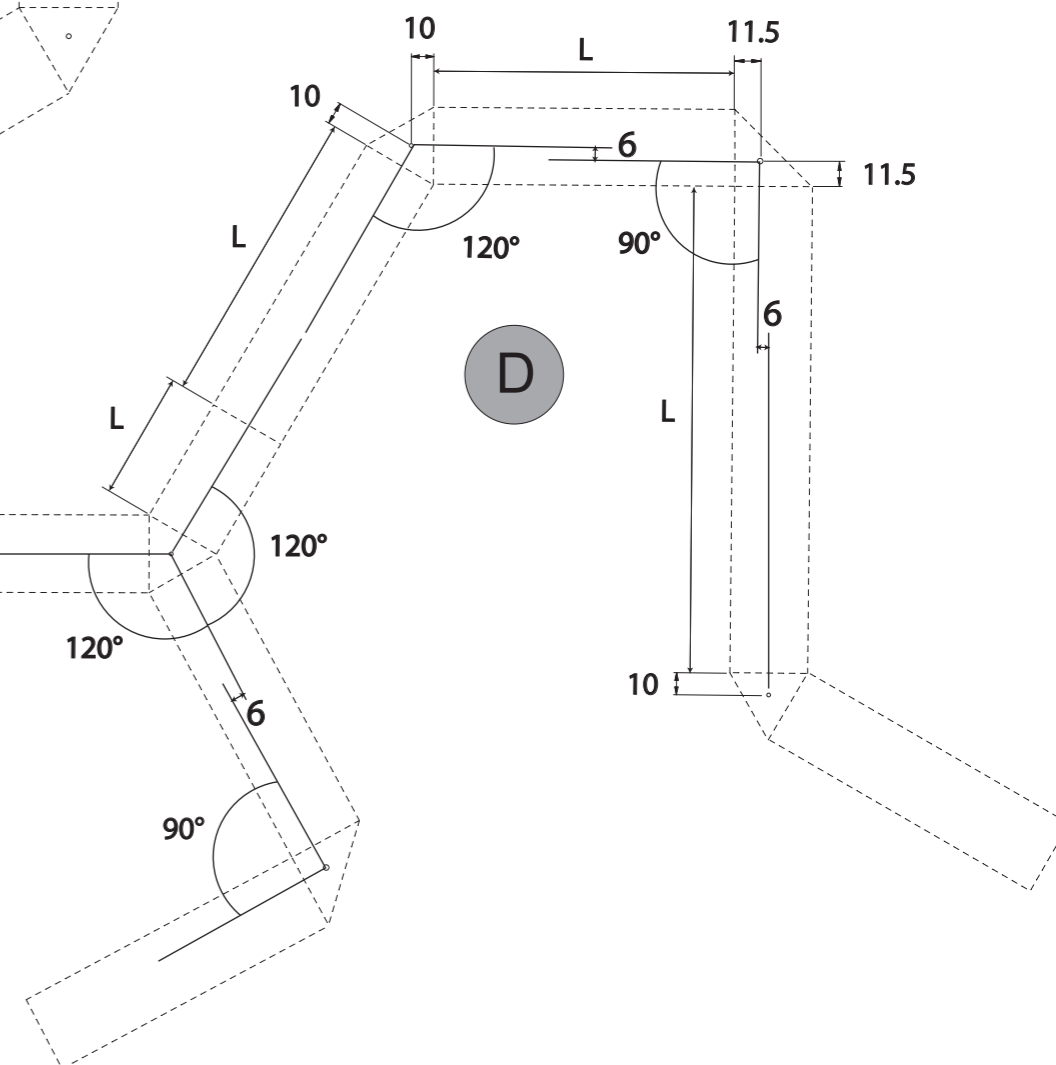
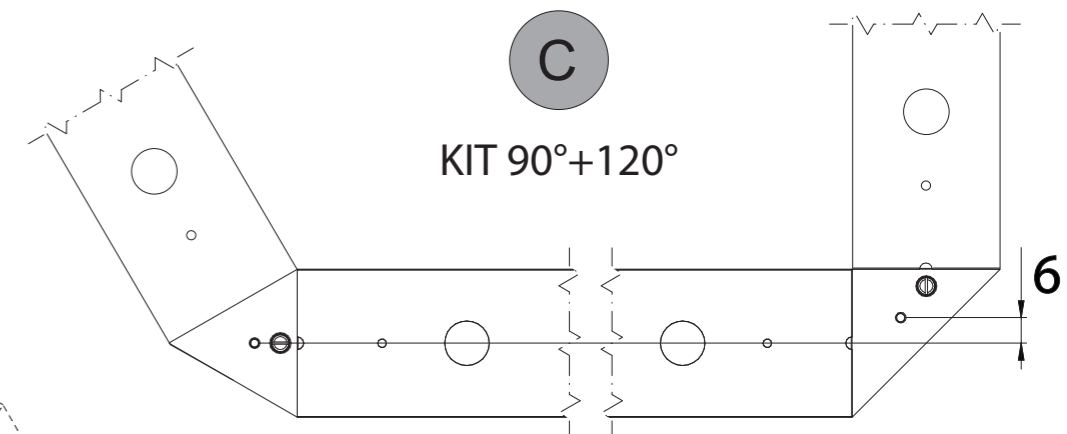
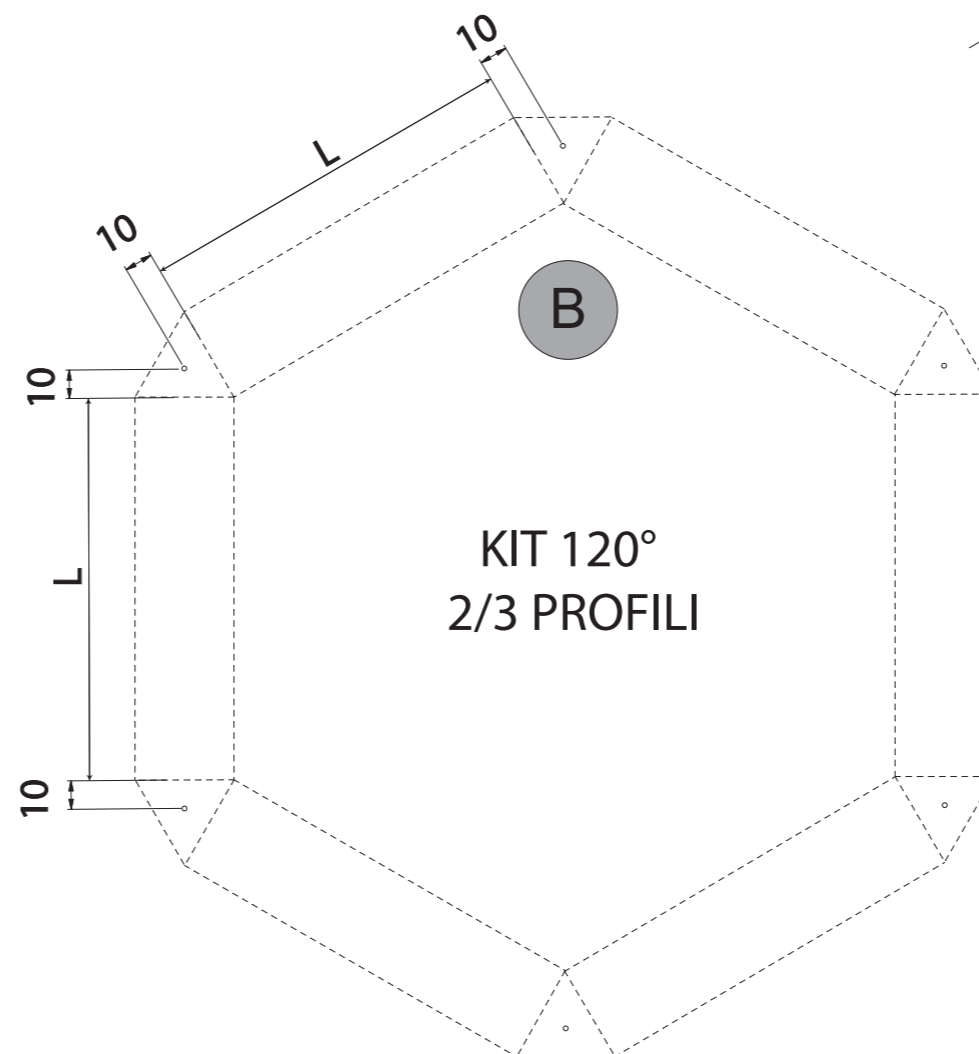
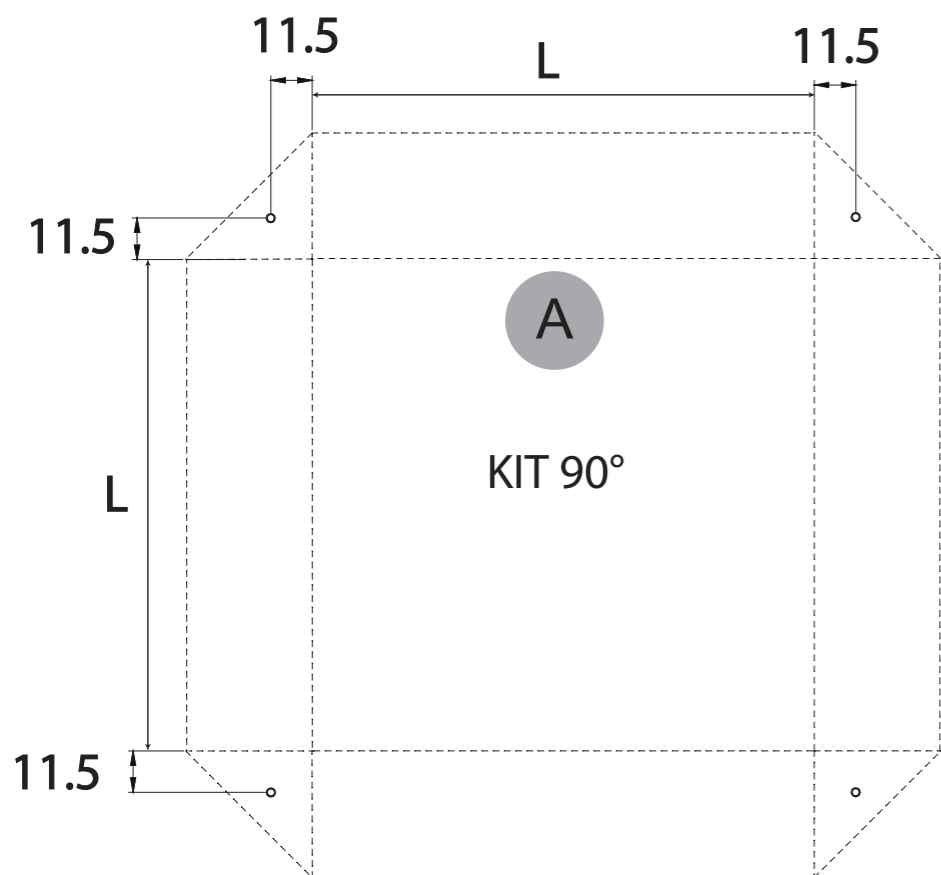

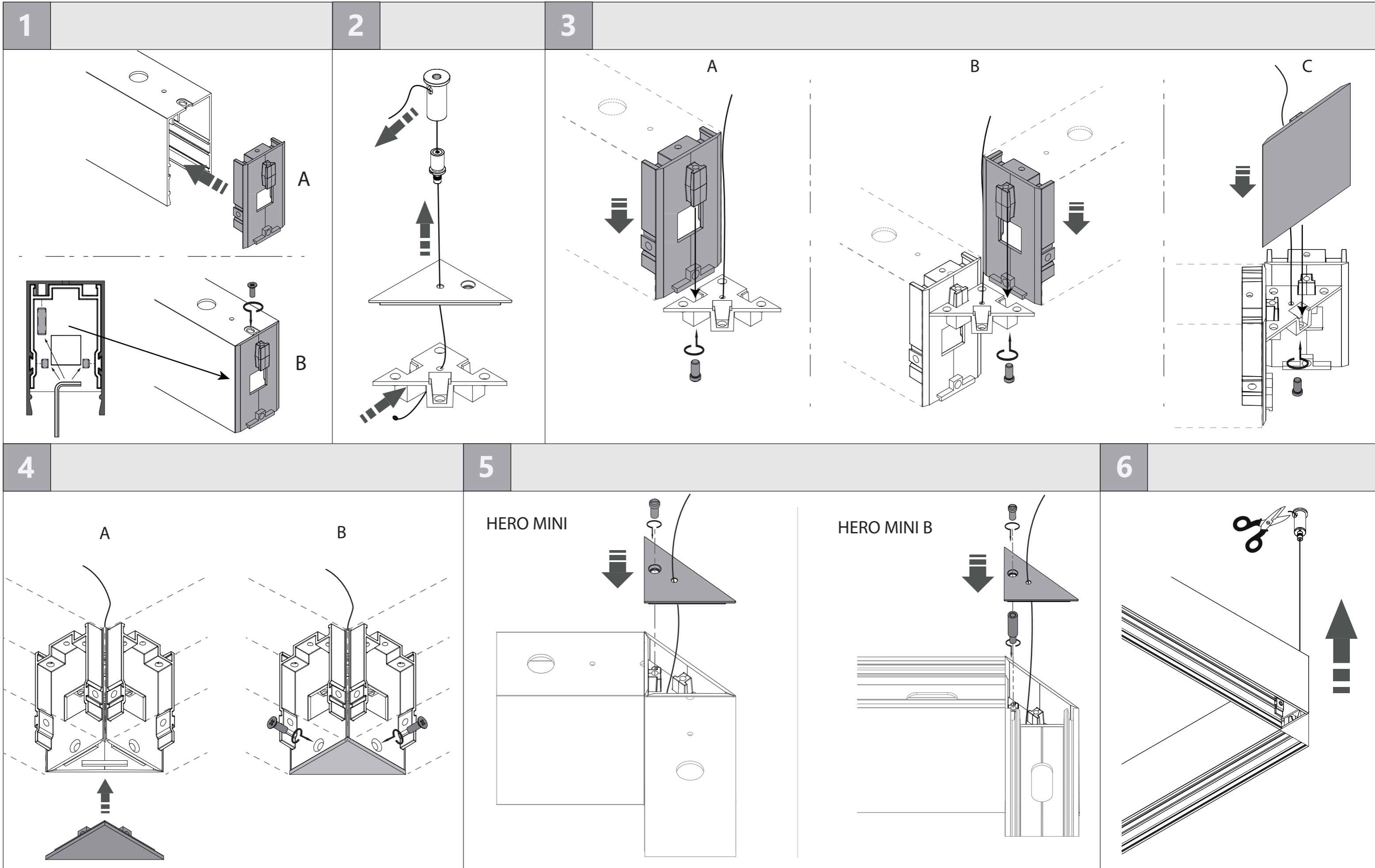
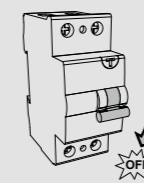

MAX 1200W
fila continua / continuous line



La sorgente luminosa contenuta in questo apparecchio deve essere sostituita solo dal costruttore o dal suo servizio di assistenza o da personale altrettanto qualificato.
The light source contained in this luminaire shall only be replaced by the manufacturer or his service agent or a similar qualified person.

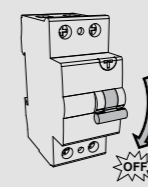

In caso di manutenzione togliere tensione.
Always switch-off the power supply before carrying out any maintenance.

Si consiglia di effettuare l'installazione a cura di personale qualificato.
The installation should be done by qualified personnel.

Alimentazione 220-240V 50/60 Hz
Power supply 220-240V 50/60 Hz

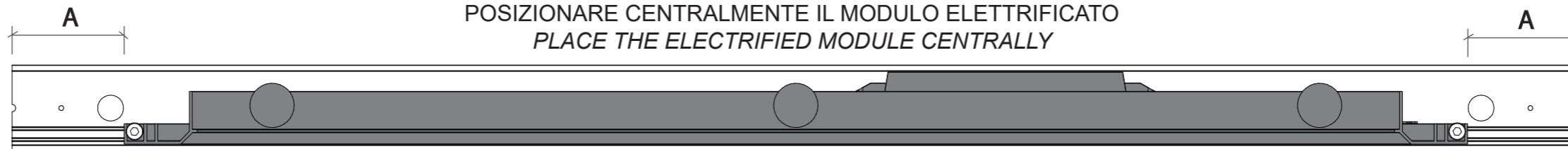

POSIZIONARE CENTRALMENTE IL MODULO ELETTRIFICATO
PLACE THE ELECTRIFIED MODULE CENTRALLY

1

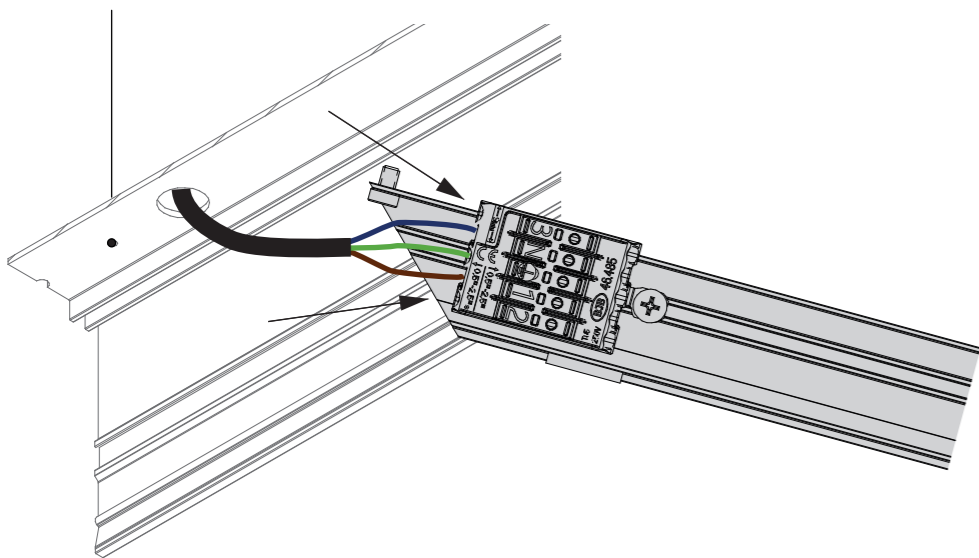

VERSIONE ON/OFF

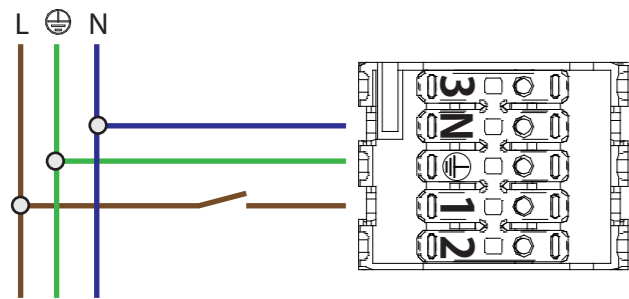

VERSIONE ON/OFF EMERGENZA

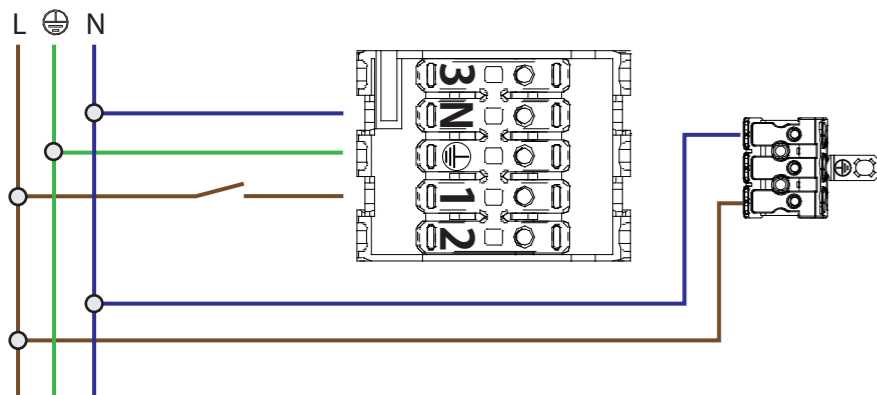

2

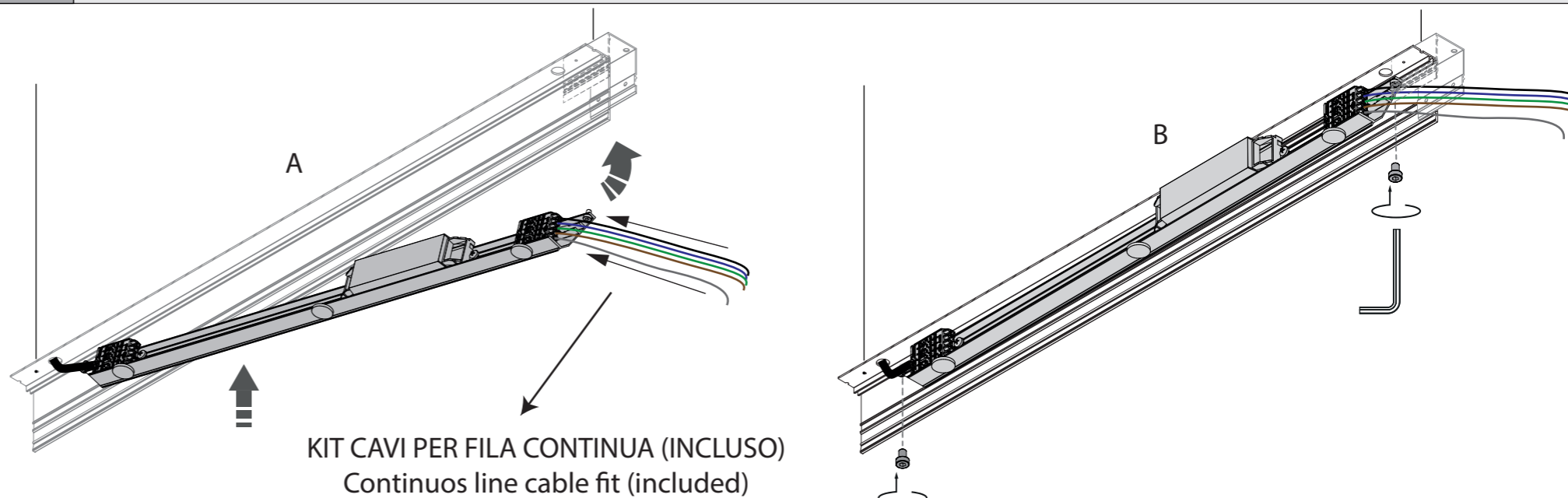

3

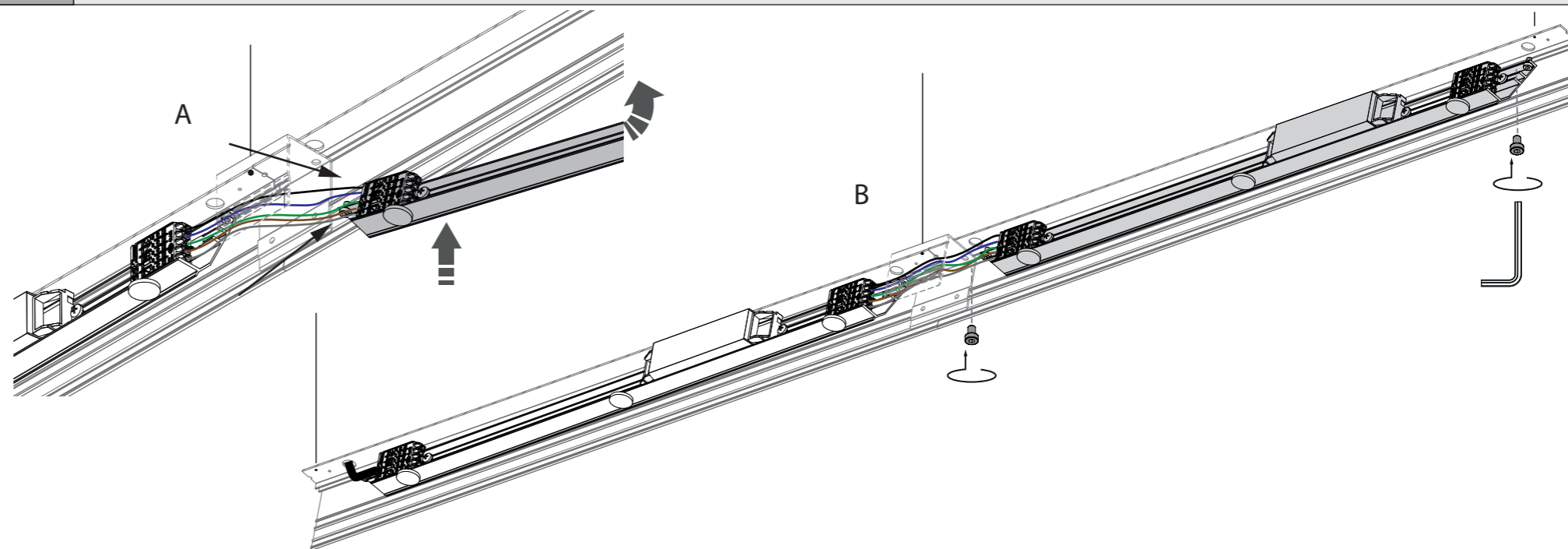

MAX 1200W
fila continua / continuous line

Ta 25°C **IP40**

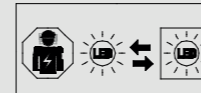

La sorgente luminosa contenuta in questo apparecchio deve essere sostituita solo dal costruttore o dal suo servizio di assistenza o da personale altrettanto qualificato.
The light source contained in this luminaire shall only be replaced by the manufacturer or his service agent or a similar qualified person.

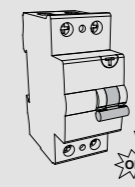
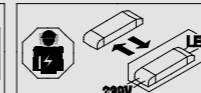

In caso di manutenzione togliere tensione.
Always switch-off the power supply before carrying out any maintenance.

Si consiglia di effettuare l'installazione a cura di personale qualificato.
The installation should be done by qualified personnel.

Alimentazione 220-240V 50/60 Hz
Power supply 220-240V 50/60 Hz

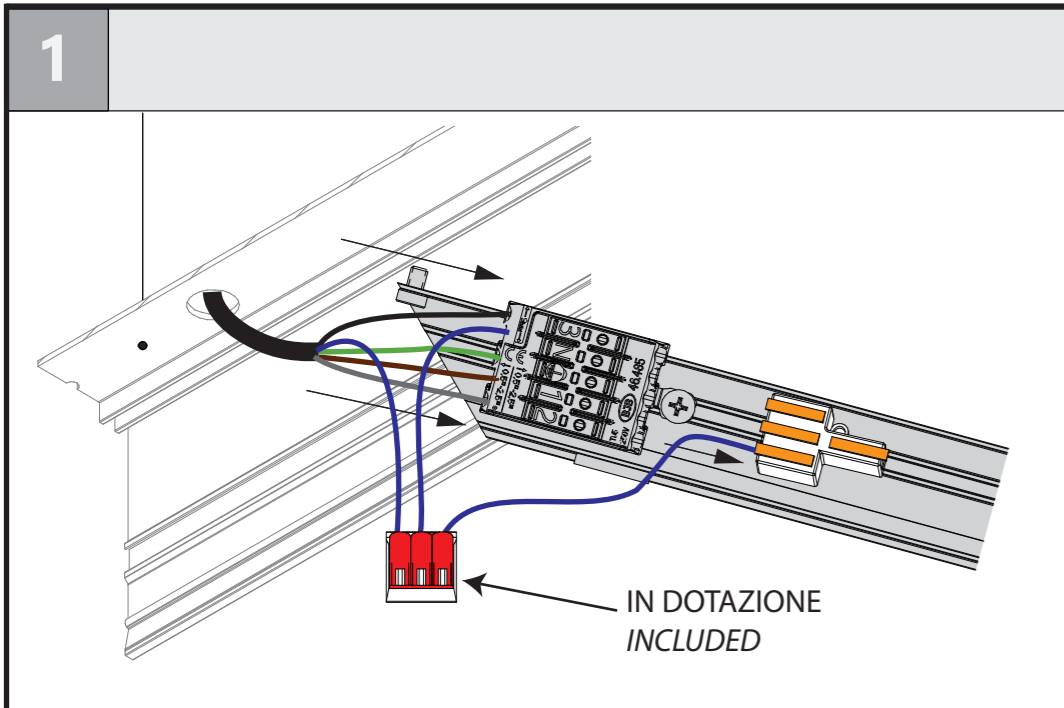
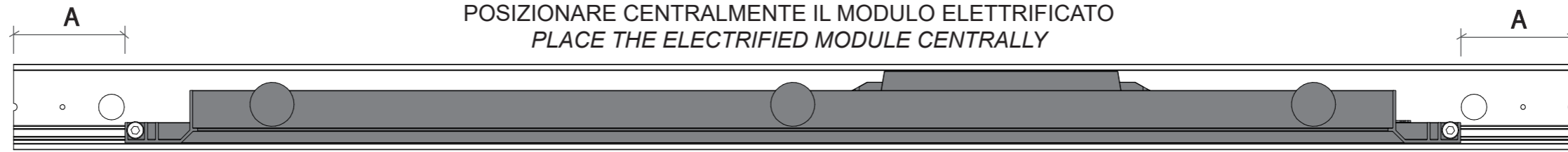

VERSIONE PUSH

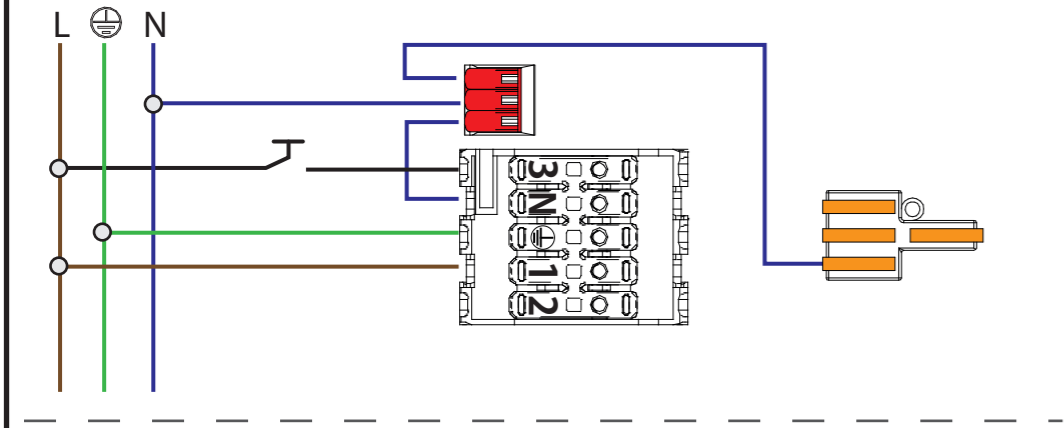

VERSIONE DALI

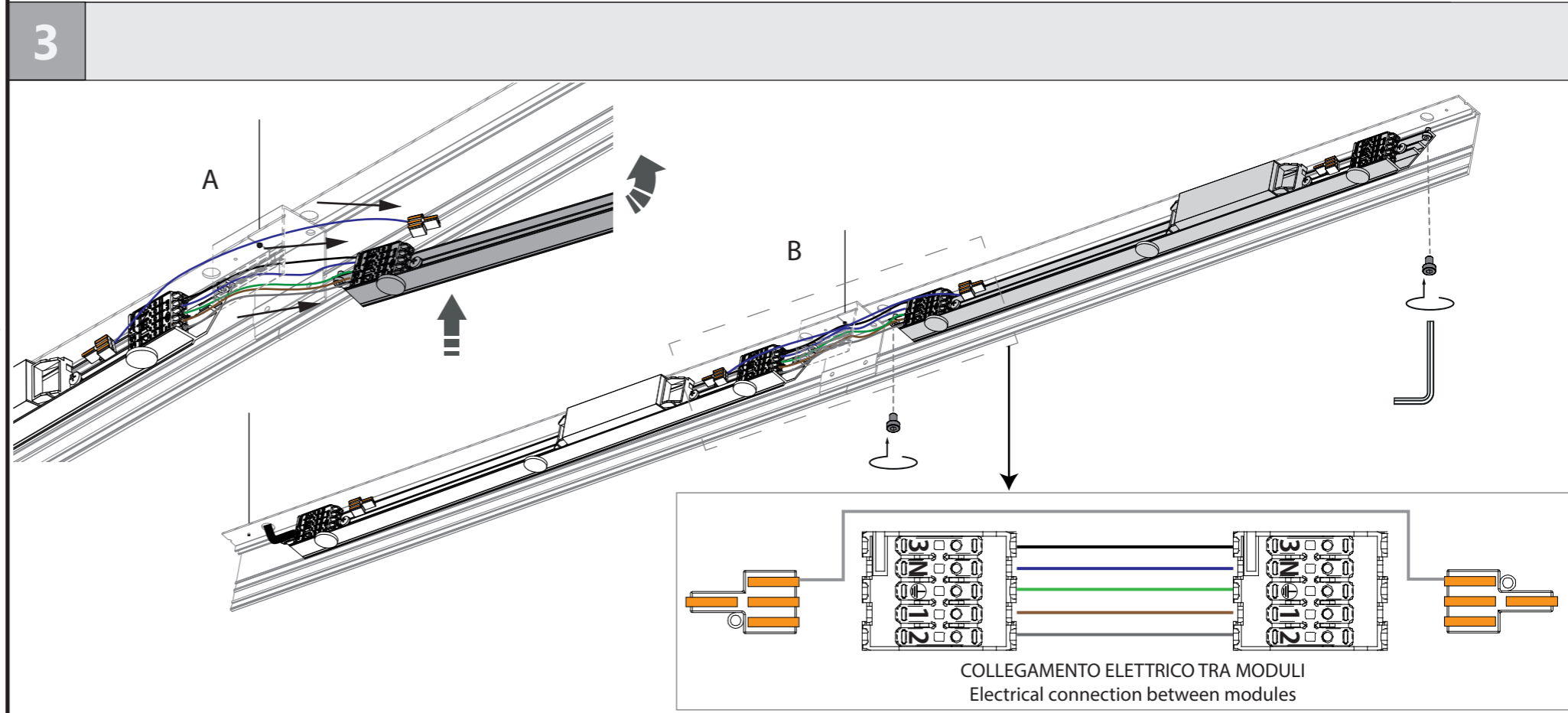
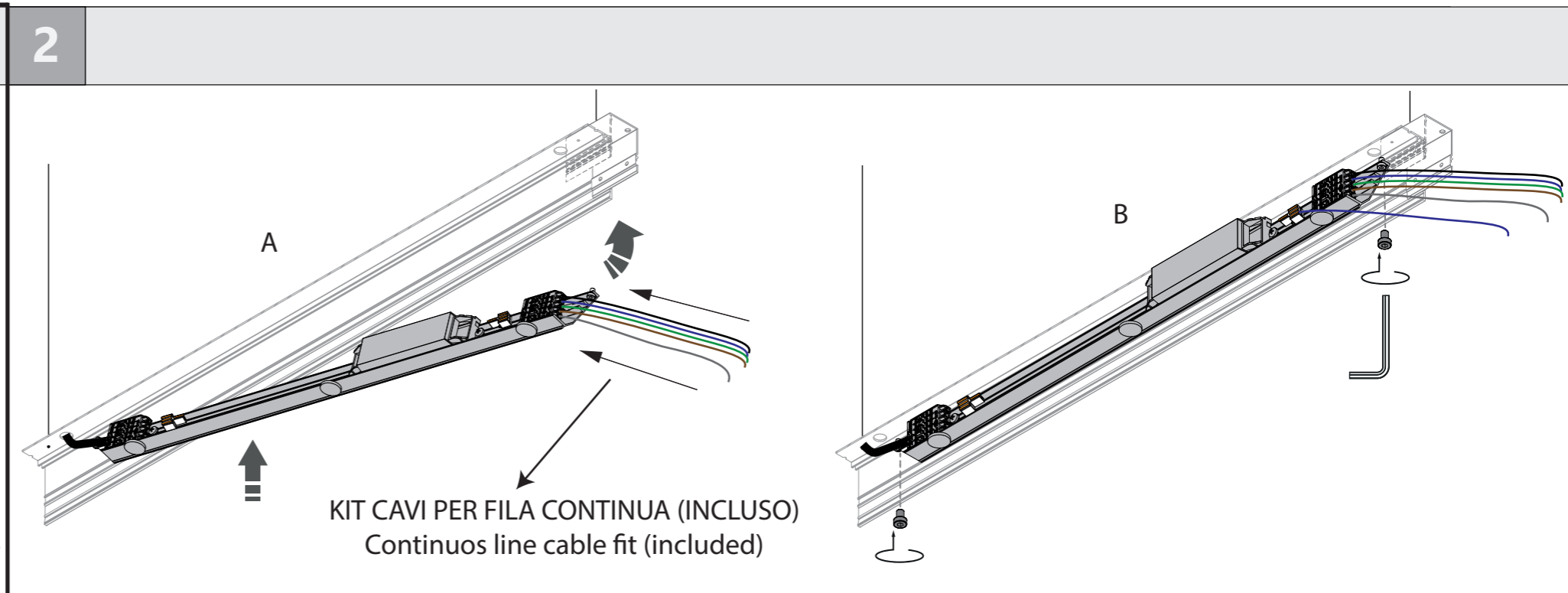
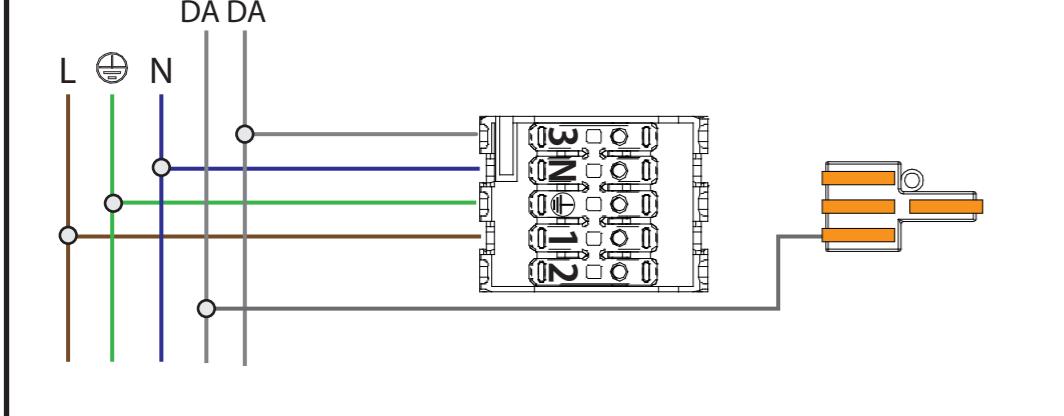



La sorgente luminosa contenuta in questo apparecchio deve essere sostituita solo dal costruttore o dal suo servizio di assistenza o da personale altrettanto qualificato.
The light source contained in this luminaire shall only be replaced by the manufacturer or his service agent or a similar qualified person.

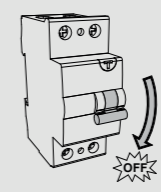

In caso di manutenzione togliere tensione.
Always switch-off the power supply before carrying out any maintenance.

Si consiglia di effettuare l'installazione a cura di personale qualificato.
The installation should be done by qualified personnel.

Alimentazione 220-240V 50/60 Hz
Power supply 220-240V 50/60 Hz **06-24**

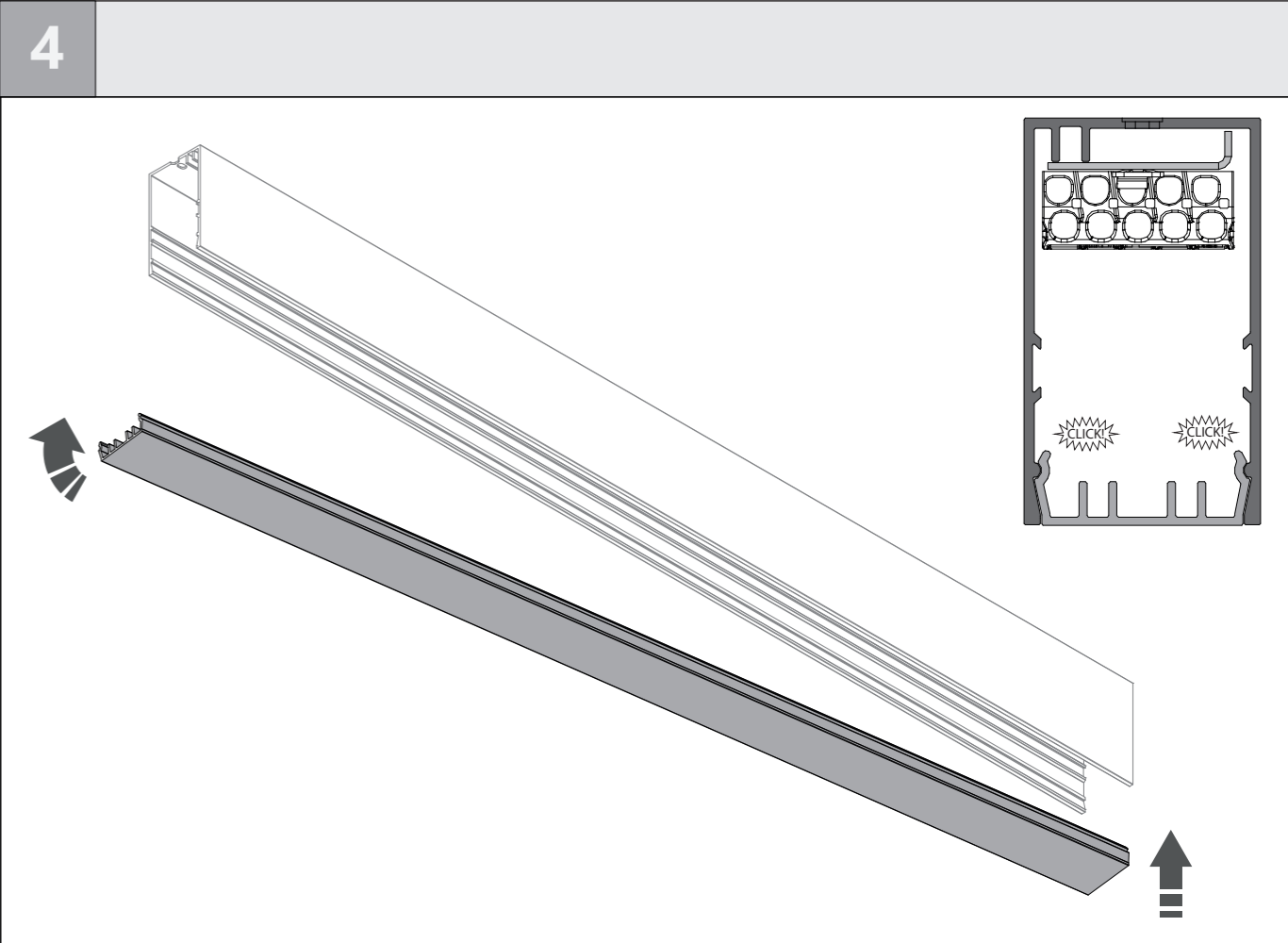
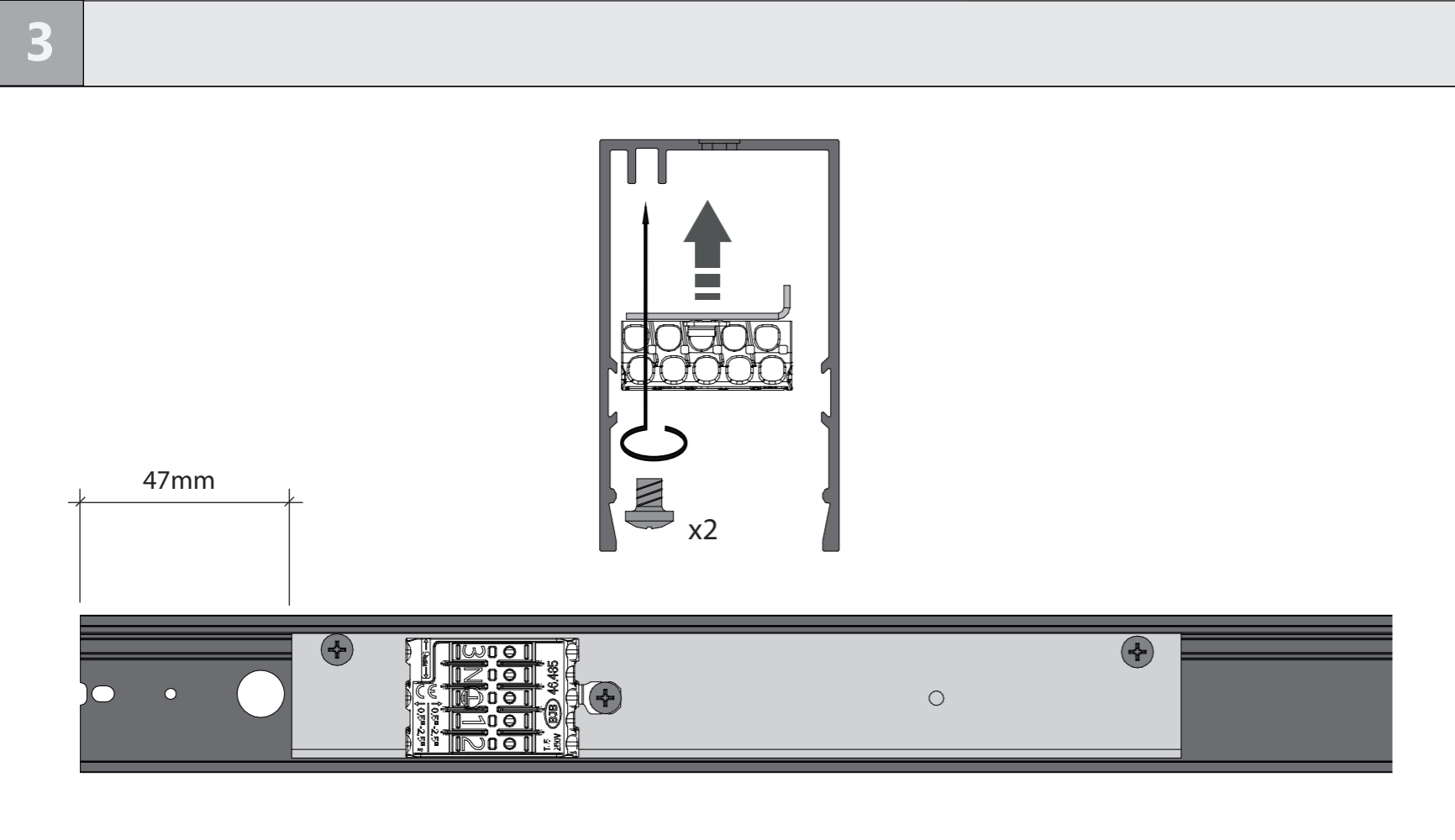
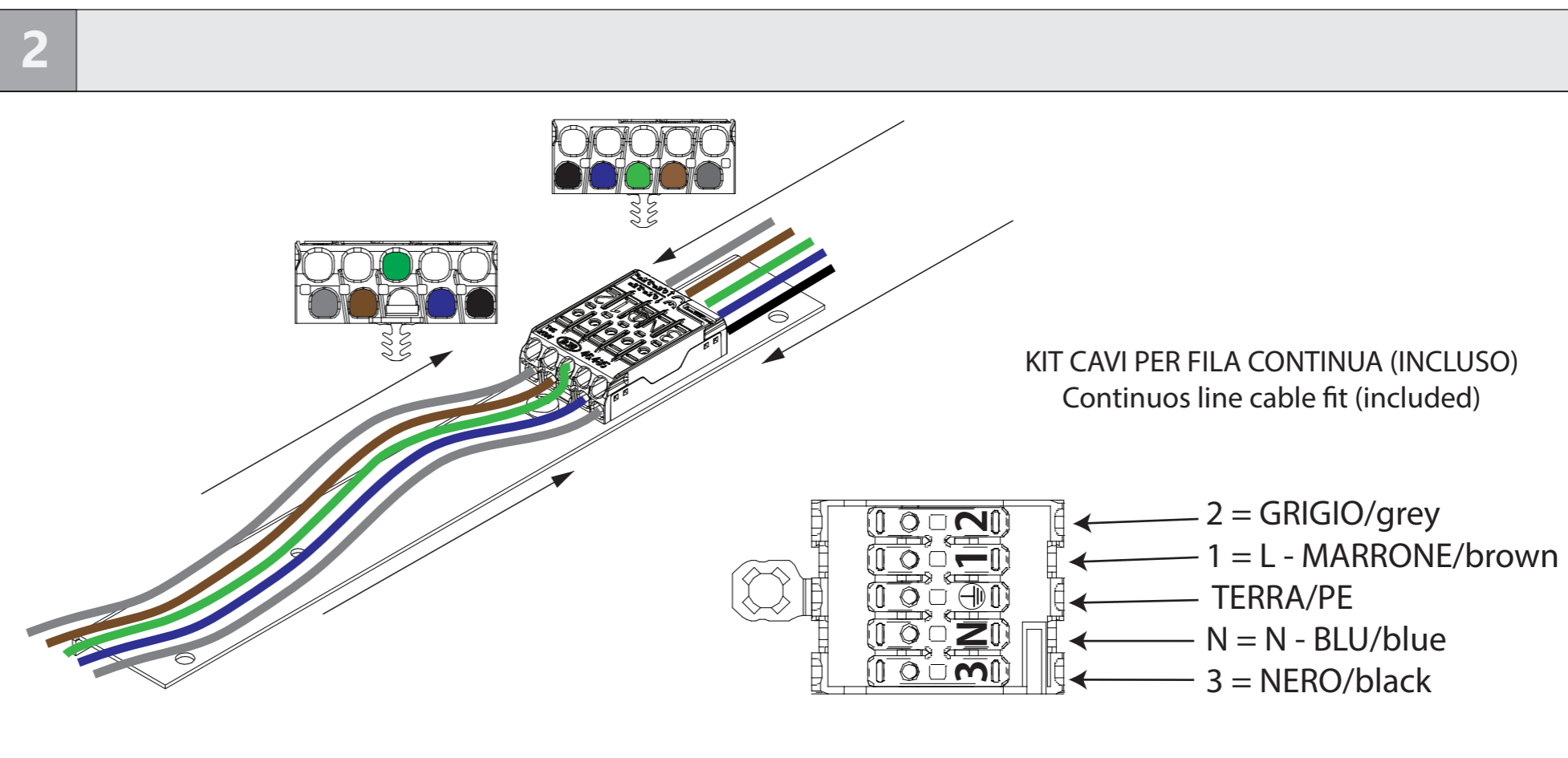
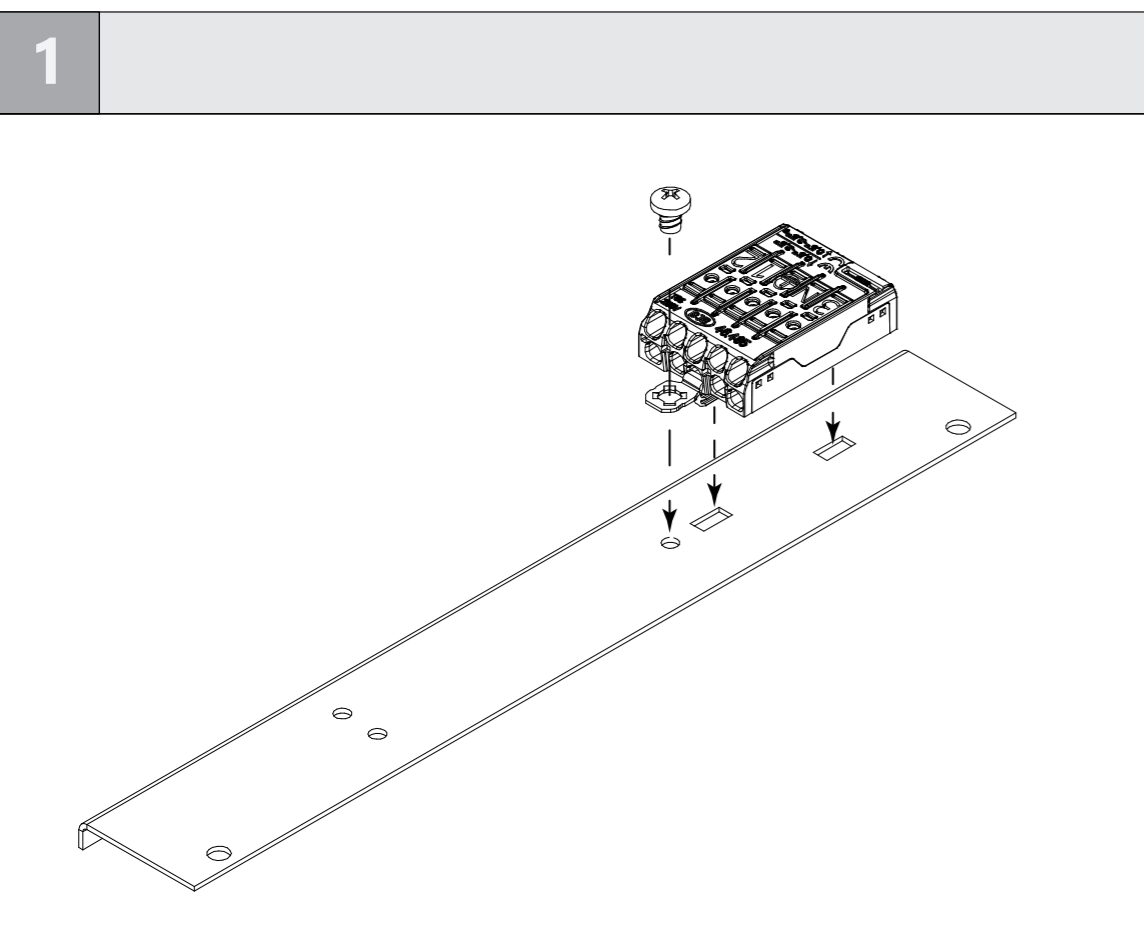

novalux

ITALIAN LIGHTING DESIGN SINCE 1948

via Marzabotto, 2 - 40050 Funo di Argelato - Bologna - Italy

IT

Direttiva 2012/19/UE (Rifiuti di Apparecchiature Elettriche ed Elettroniche RAEE):

Il simbolo del cassonetto barrato riportato sull'apparecchiatura o sulla sua confezione indica che il prodotto alla fine della propria vita utile deve essere raccolto separatamente dagli altri rifiuti. L'utente dovrà, pertanto, conferire l'Apparecchiatura giunta a fine vita agli idonei centri di raccolta differenziata dei Rifiuti Elettronici ed Elettrotecnici, oppure riconsegnarla al rivenditore al momento dell'acquisto di una nuova apparecchiatura di tipo equivalente, in ragione di uno a uno. L'adeguata raccolta differenziata per l'avvio successivo dell'apparecchiatura dismessa al riciclaggio, al trattamento ed allo smaltimento ambientalmente compatibile contribuisce ad evitare possibili effetti negativi sull'ambiente e sulla salute e favorisce il reimpiego e/o riciclo dei materiali di cui è composta l'apparecchiatura. Lo smaltimento abusivo del prodotto da parte dell'utente comporta l'applicazione delle sanzioni amministrative previste dalla normativa vigente.

ES

Directiva 2012/19/UE (Residuos de aparatos eléctricos y elec-trónicos RAEE): Información para el usuario.

Este producto es conforme con la Directiva EU 2012/19/UE. El simbolo de la papelera barrada situado sobre el aparato indica que este producto, al final de su vida útil, debe ser tratado separadamente de los residuos domésticos. El usuario es responsable de la entrega del aparato al final de su vida útil a los centros de recogida autorizados. El adecuado proceso de recogida diferenciada permite dirigir el aparato desechado al reciclaje, a su tratamiento y a su desmantelamiento de una forma compatible con el medio ambiente, contribuyendo a evitar los posibles efectos negativos sobre el ambiente y la salud, favoreciendo el reciclaje de los materiales de los que está compuesto el producto. Para información más detallada inherente a los sistemas de recogida disponibles, dirigirse al servicio local de recogida o al establecimiento donde se adquirió el producto.

FR

Directive 2012/19/UE (Déchets d'équipements électriques et électroniques DEEE): informations aux utilisateurs.

Ce produit est conforme à la Directive ED 2012/19/UE. Le symbole de la corbeille barrée reporté sur l'appareil indique que ce dernier doit être éliminé à part lorsqu'il n'est plus utilisable et non pas avec les ordures ménagères. L'utilisateur a la responsabilité de porter l'appareil hors d'usage à un centre de ramassage spécialisé. Le tri approprié des déchets permet d'acheminer l'appareil vers le recyclage, le traitement et l'élimination de façon écologiquement compatible. Il contribue à éviter les effets négatifs possibles sur l'environnement et sur la santé, tout en favorisant le recyclage des matériaux dont est constitué le produit. Pour avoir des informations plus détaillées sur les systèmes de ramassage disponibles, s'adresser au service local d'élimination des déchets ou au revendeur.

DE

Richtlinie 2012/19/UE (Elektronikaltgeräte WEEE): Benutzerinformationen.

Dieses Produkt entspricht der EU-Richtlinie 2012/19/UE. Das Symbol des auf dem Gerät dargestellten, durchgestrichenen Korbesgibt an, dass das Produkt am Ende seiner Nutzungsdauer gesondert vom Hausmüll zu behandeln ist. Am Ende der Nutzungsdauer ist der Benutzer für die Überantwortung des Geräts an geeignete Sammelstellen verantwortlich. Die angemessene, getrennte Müllsammlung zwecks umweltkompatibler Behandlung und Entsorgung für den anschließenden Recyclingbeginn des nicht mehr verwendeten. Geräts trägt zur Vermeidung möglicher schädlicher Wirkungen auf Umwelt und Gesundheit bei und begünstigt das Recycling der Materialien, aus denen das Produkt zusammengesetzt ist. Für nähere Informationen bezüglich der zur Verfügung stehenden Sammelsysteme, wenden Sie sich bitte an den örtlichen Müllentsorgungsdienst oder an das Geschäft, in dem der Kauf getätigt worden ist.

UK

Directive 2012/19/UE (Waste Electrical and Electronic Equipment WEEE): information for users.

This product complies with EU Directive 2012/19/UE. The crossed-out wastebasket symbol on the appliance means that at the end of its useful lifespan, the product must be disposed of separately from ordinary house-hold wastes. The user is responsible for delivering the appliance to an appropriate collection facility at the end of its useful lifespan. Appropriate separate collection to permit recycling, treatment and environmentally compatible disposal helps prevent negative impact on the environment and human health and promotes recycling of the materials making up the product. For more information on available collection facilities, contact your local waste collection service or the shop where you bought this appliance.

NL

Richtlijn 2012/19/UE (Afgedank-te Elektrische en Elektronische Apparaten AEEA): informatie voor de gebruikers.

Dit product voldoet aan de richtlijn EU 2012/19/UE. Het symbool van de vuilnisbak met een streep erdoor, dat op het apparaat staat, geeft aan dat het product, wanneer het wordt afgedankt, niet met het huisvuil kan worden meegegeven. Het is de verantwoordelijkheid van de gebruiker het product, op het moment dat dit wordt afgedankt, in te leveren bij een centrum voor gescheiden afvalverwerking. Een correcte gescheiden afvalverwerking, die gericht is op de recycling van het afgedankte product en die een milieuvriendelijke behandeling en vernietiging mogelijk maakt, draagt ertoe bij mogelijk negatieve effecten op het milieu en op de gezondheid te voorkomen en bevordert het hergebruik van de materialen waaruit het product bestaat. Voor meer gedetailleerde informatie met betrekking tot de voorhanden zijnde afvalverwerkingsystemen dient u zich te wenden tot de plaatselijke vuilnisdienst of tot de winkelier waar u het product heeft gekocht.

PT

Directiva 2012/19/UE (Resíduos de equipamentos eléctricos e electrónicos REEE):informações para os utilizadores.

Este produto é conforme à Directiva EU 2012/19/UE. O simbolo do cesto barrado marcado no aparelho indica que o produto, no fim da própria vida útil, deve ser tratado separadamente do lixo doméstico. O utilizador é responsável pela entrega do aparelho, no fim da vida do mesmo, às apropriadas estruturas de recolha. A adequada recolha diferenciada para o encaminhamento sucessivo do aparelho à reciclagem, ao tratamento e ao escoamento ambientalmente compatível, contribui para evitar possíveis efeitos negativos sobre o ambiente e a saúde e favorece a reciclagem dos materiais que compõem o produto. Para informações mais detalhadas inerentes aos sistemas de recolha disponíveis, dirija-se ao serviço local de escoamento de resíduos, ou a loja na qual efectuou a compra.

NO

WEEE-symbolet (Waste Electrical and Electronic Equipment).

Bruken av WEEE-symbolet indikerer at dette produktet ikke kan behandles som husholdningsavfall. Du vil bidra til å beskytte miljøet ved å sørge for at dette produktet blir avhendet på en forsvarlig måte. Ta kontakt med kommunale myndigheter, renovasjons-selskapet der du bor eller forretningen hvor du kjøpte produktet for å få mer informasjon om resirkulering av dette produktet.

SV

Symbol för avfall från elektrisk och elektronisk utrustning (WEEE).

Märkning med WEEE-symbolen visar att produkten inte får behandlas som hushållsavfall. Genom att slänga den här produkten på rätt sätt bidrar du till att skydda miljön. Mer information om återvinning av produkten kan du få av de lokala myndigheterna, din renhållningsservice eller i affären där du köpte produkten.

FI

WEEE-merkintä (sähköja elektro-niikkalaiteromu).

WEEE-merkintä osoittaa, että tätä tuotetta ei voi käsitellä kotitalousjätteen tavoin. Kun huolehdit tämän tuotteen asianmukaisesta hävittämisestä, autat suojelemaan ympäristöä. Lisätietoja tämän tuotteen kierrättämisestä saat paikallisviranomaisilta, jätehuolto-yhtiöltäsi tai myymälästä josta ostit tämän tuotteen.

DA

Symbol for affald af elektrisk og elektronisk udstyr (WEEE)

Brugen af WEEE-symbolet betyder, at dette produkt ikke må behandles som husholdningsaffald. Ved at sørge for korrekt bortskaffelse af produktet medvirker du til at beskytte miljøet. Du kan få flere oplysninger om genbrug af dette produkt hos de lokale myndigheder, dit renovations-selskab eller i forretningen, hvor du har købt produktet.

HU

Hulladék elektromos vagy elektronikus készüléket jelölő szimbólum.

Ez a szimbólum azt jelöli, hogy a terméket nem szabad háztartási hulladékként kezelni. A hulladékká vált terék megfelelő elhelyezésével hozzájárul a környezet védelméhez. A termék újrafelhasználásával kapcsolatban a helyi szerveknél háztartási hulladékokat elszállító vállalatnál vagy a terméket értékesítő üzletben tájékozódhat.

CZ

Symbol pro odpadní elektrický a elektronický materiál (WEEE).

Použití symbolu WEEE označuje, že tento produkt nelze likvidovat jako domovní odpad. Správnou likvidaci tohoto produktu můžete najít u ochrany životního prostředí. Podrobnější informace o likvidaci tohoto produktu vám poskytne místní úřad, společenství pro likvidaci komunálního odpadu nebo obchod, kde jste zboží zakoupili.

GR

Οδηγία 2012/19/UE (Απόβλητα Ειδών Ηλεκτρικού και Ηλεκτρονικού Εξοπλισμού ΑΗΗΕ):

πληροφορίες για τους χρήστες: βάσει του άρθρου 13 του Νομοθετικού Διατάγματος της 25ης Ιουλίου 2005, αρ. 151 "Εφαρμογή των Οδηγιών 2002/95/ΕΚ, 2012/19/UE και 2003/108/ΕΚ, σχετικά με τον περιορισμό της χρήσης επικίνδυνων ουσιών σε είδη ηλεκτρικού και ηλεκτρονικού εξοπλισμού, καθώς και με τη διάθεση των αποβλήτων", το παρόν προϊόν είναι κατάλληλο. Το σύμβολο του διαγραφόμενου κάδου που παρατίθεται επί της συσκευής ή επί της συσκευασίας υποδεικνύει ότι το προϊόν στο τέλος της ωφέλιμης ζωής του πρέπει να συλλεχθεί χωριστά από τα άλλα απορρίμματα. Ο χρήστης θα πρέπει κατά επέκταση να παραδίει τη συσκευή, που φτάνει στο τέλος της ζωής της, σε ενδεδειγμένα κέντρα επιλεκτικής συλλογής των ηλεκτρονικών κι ηλεκτροτεχνικών απορριμμάτων, ή να την επιστρέφει στις αντιπροσωπείες τη στιγμή της αγοράς μίας καινούριας συσκευής παρεμφερούς τύπου, στην αναλογία ένα προς ένα. Η ενδεδειγμένη επιλεκτική συλλογή για την εν συνεχεία προώθηση της εκτός λειτουργίας, επεξεργασία και περιβαλλοντικά συμβατή αποκομιδή συνεισφέρει στην αποτροπή πιθανών αρνητικών επιπτώσεων για το περιβάλλον και την υγεία και προάγει την επαναχρησιμοποίηση και/ή ανακύκλωση των υλικών από τα οποία αποτελείται η συσκευή. Η ανεξέλεγκτη αποκομιδή του προϊόντος από τον χρήστη προϋποθέτει την εφαρμογή των διοικητικών κυρώσεων σύμφωνα με το νόμο.

PL

Dyrektywa 2012/19/UE (Odpady z aparatury elektrycznej i elektronicznej RAEE):

Symbol przekreślonej skrzyni umieszczony na aparaturze ze lub na jej opakowaniu wskazuje, że produkt po zakończeniu możliwej eksploatacji powinien być usunięty oddzielnie od innych odpadów. Użytkownik ma w związku z tym obowiązek oddania aparatury wycofanej z eksploatacji do odpowiednich ośrodków przystosowanych dla odpadów elektronicznych i elektrotechnicznych lub dostarczyć je do sprzedawcy w momencie zakupu nowej ekwiwalentnej aparatury, na zasadzie jeden za jeden. Odpowiednia selekcja odpadów, które zostaną następnie przesłane do recyklingu, obróbki a następnie do likwidacji środowiskowo zgodnej eliminuje negatywne skutki dla środowiska i dla zdrowia i ułatwia ponowne zastosowanie i/lub recykling materiałów, z których jest zbudowana aparatura. Nielegalna likwidacja produktu ze strony użytkownika podlega sankcjom administracyjnym zgodnie z obowiązującymi przepisami prawa.

RM

Directiva 2012/19/UE (Deșeurile de



Echipamente Electrice și Electronice DEEE):

Simbolul tomberonului tăiat care apare pe echipamente sau pe ambalaj vă arată că aceste produse la scoaterea lor din uz trebuie să fie colectate separat de celelalte deșeurile. Va fi deci necesar ca și consumatorii să încredințeze Echipamentele scoase din uz Centrelor de Colectare diferențiată a Deșeurilor Echipamentelor Electrice și Electronice sau să le dea la schimb vânzătorilor de la care le-au cumpărat, în momentul în care doresc să achiziționeze un aparat echivalent. Colectarea diferențiată adecvată, în vederea reciclării, tratării și eliminării deșeurilor în mod compatibil, contribuie la evitarea posibilelor impacturi negative asupra mediului înconjurător și sănătății, favorizând în același timp reutilizarea/reciclarea materialelor componente ale echipamentelor. Eliminarea abuzivă a produselor de către consumator i va atrage după sine sancționarea administrativă pre-văzută de normele în