

# ZENIT

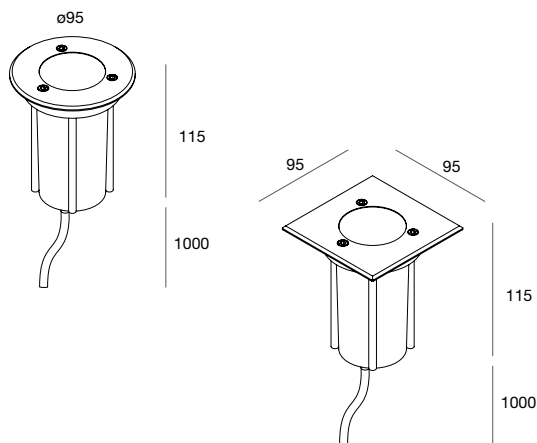

Apparecchio LED IP67 calpestabile, da incasso a terra, a tensione di rete con ottica fissa con riflettore 15° o 50°. Corpo in lega di alluminio anodizzata e verniciata a polvere, cornice tonda o quadrata in acciaio inox AISI 316 spazzolato e vetro temperato. Provvisto di cavo H05RN-F 3X1 mm<sup>2</sup> di lunghezza 1m. Viteria inox ed alimentatore elettronico incorporato. Cassaforma da ordinare a parte. Resistenza al carico statico (per installazione su pavimentazione) pari a 2.000kg. Temperatura di contatto <65°C.

LED floor recessed luminaire IP67 walkable, with fixed optics and with 15° or 50° reflector, for operation with mains voltage. Body in anodized and powder coated aluminium alloy, round or square frame made of brushed stainless steel AISI 316 and tempered glass. Equipped with cable H05RN-F 3X1 mm<sup>2</sup> length 1m. Stainless steel screws and built-in electronic driver. Recessed box to be ordered separately. Resistance to static load (for installation on a pavement) of 2.000kg. Contact temperature 65 °C.



## TONDO

			3000K
15°	5W	353 lm	<b>111301.09</b>
50°	5W	359 lm	<b>111302.09</b>

## QUADRATO

			3000K
15°	5W	353 lm	<b>111303.09</b>
50°	5W	359 lm	<b>111304.09</b>

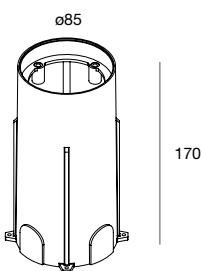

**CASSAFORMA**  
In polietilene.  
Accessorio obbligatorio.

**RECESSED BOX**  
Made of polyethylene.  
Mandatory accessory.

**111305.99**